

## Adjustable Spreader Lifting Beam 1000 lb / 0.5 ton - 72 in Max Spread

### Key features

- Load Capacity: Safely lifts loads up to 1000 lbs (0.5 tons), suitable for medium-duty lifting tasks.
- Adjustable Spread: Maximum spread of 72 inches allows for flexibility in handling different load sizes and configurations.
- Durable Construction: Made from high-quality materials to ensure strength and durability for long-lasting performance.
- 3 Year Warranty, Customer Support and Service in the USA

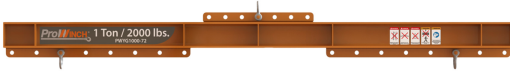

### Adjustable Spreader Beam Description

The Adjustable Spreader Lifting Beam is a versatile lifting solution designed for safely handling loads up to 1000 lbs (0.5 tons). With a maximum adjustable spread of 72 inches, this beam ensures even weight distribution, making it ideal for a variety of industrial and construction applications.

## Technical Specifications

<b>Rated Load Capacity</b>	1000 lbs / 0.5 tons	<b>Warranty</b>	3 Year
<b>Standards Compliance</b>	ASME B30.20 AND ASME BTH-1		

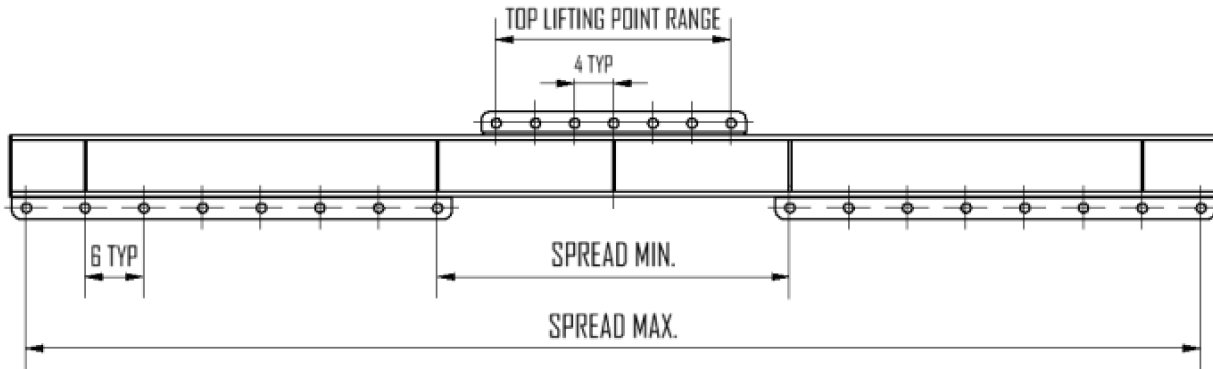
**PWYG**

MODEL	Cap (lb)	MAX SPREAD (in)	MIN SPREAD (in)	TOP LIFTING POINT RANGE (in)	WEIGHT (lbs)
PWYG1000-48	1000	48	12	16	81
PWYG1000-72	1000	72	36	16	111
PWYG1000-96	1000	96	36	24	151
PWYG1000-120	1000	120	36	24	186
PWYG2000-48	2000	48	12	16	83
PWYG2000-72	2000	72	36	24	116
PWYG2000-96	2000	96	36	24	192
PWYG2000-120	2000	120	36	24	239
PWYG4000-48	4000	48	12	16	105
PWYG4000-72	4000	72	36	24	149
PWYG4000-96	4000	96	36	24	241
PWYG4000-120	4000	120	36	24	364
PWYG8000-72	8000	72	36	32	285
PWYG8000-96	8000	96	36	32	375
PWYG8000-120	8000	120	36	32	537