

Adjustable Spreader Lifting Beam 1000 lb / 0.5 ton - 120 in Max Spread

Key features

- Load Capacity: Safely lifts loads up to 1000 lbs (0.5 tons), suitable for medium-duty lifting tasks.
- Adjustable Spread: Maximum spread of 120 inches allows for flexibility in handling different load sizes and configurations. Spread
- Durable Construction: Built from high-quality materials to ensure strength, stability, and long-lasting performance.
- 3 Year Warranty, Customer Support and Service in the USA

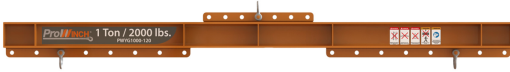

Adjustable Spreader Lifting Beam Description

The Adjustable Spreader Lifting Beam is a versatile lifting solution designed for handling heavy loads with a maximum capacity of 1000 lbs (0.5 tons). With an adjustable spread of up to 120 inches, this beam is perfect for lifting and distributing weight evenly across multiple points, making it ideal for various industrial and construction applications.

Technical Specifications

Rated Load Capacity	1000 lbs / 0.5 tons	Warranty	3 Year
Standards Compliance	ASME B30.20 AND ASME BTH-1		

PWYG

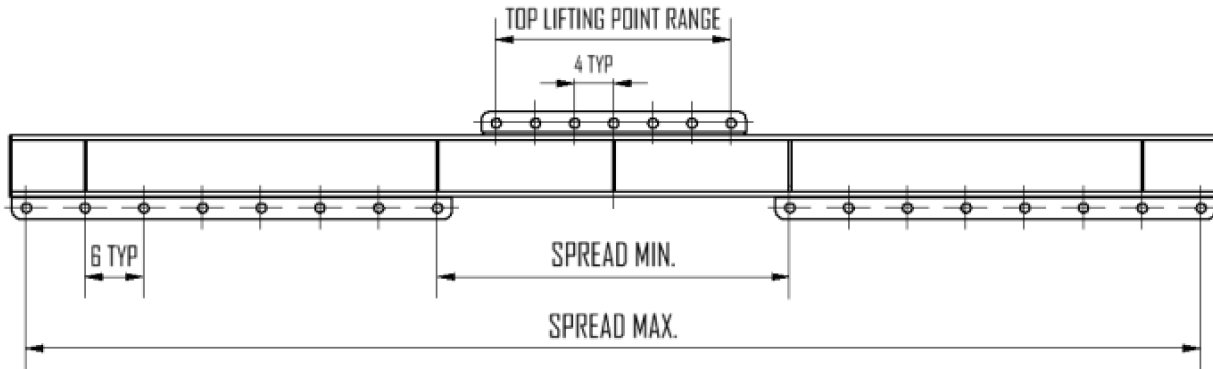

MODEL	Cap (lb)	MAX SPREAD (in)	MIN SPREAD (in)	TOP LIFTING POINT RANGE (in)	WEIGHT (lbs)
PWYG1000-48	1000	48	12	16	81
PWYG1000-72	1000	72	36	16	111
PWYG1000-96	1000	96	36	24	151
PWYG1000-120	1000	120	36	24	186
PWYG2000-48	2000	48	12	16	83
PWYG2000-72	2000	72	36	24	116
PWYG2000-96	2000	96	36	24	192
PWYG2000-120	2000	120	36	24	239
PWYG4000-48	4000	48	12	16	105
PWYG4000-72	4000	72	36	24	149
PWYG4000-96	4000	96	36	24	241
PWYG4000-120	4000	120	36	24	364
PWYG8000-72	8000	72	36	32	285
PWYG8000-96	8000	96	36	32	375
PWYG8000-120	8000	120	36	32	537