



## 3 Ton Lever Chain Hoist 10 ft G80 Chain

### Key features

- Durable Black Tempered G80 Load Chain
- Reinforced Gear Cover, Zinc Plated Chain Guide and Side Plates
- CE Certified by TUV Rheinland
- Reliable and Stable Double Pawl Brake System, Tested at 125% of Load Capacity
- 3 Year Warranty, Customer Support and Service in the USA

### Lever Chain Hoist Description

The **Prowinch 3 ton Lever Chain Hoist** features a heavy duty and durable design that offers powerful lifting capabilities in a portable size. It is an excellent choice for a wide variety of environments, such as warehouses, auto shops, and construction sites.

### Prowinch Lever Chain Hoist

All of our **Lever Chain Hoists** are created with the goal of offering the best price-performance ratio. Key components such as lifespan factors are constantly tested and improved in order to offer the best product for the price.

### Braking System

The reliable double pawl brake system is tested at 125% of the hoist capacity.

## Technical Specifications

<b>Rated Load Capacity</b>	6610 lb / 3000 kg	<b>Load Chain Size</b>	Ø10 mm
<b>Standard Lifting Height</b>	5 ft / 1.5 m	<b>Chain Falls</b>	1
<b>Capacity Range</b>	4	<b>Standards Compliance</b>	ANSI/ASME B30.21, EN13157, ISO 16877-2008
<b>Lever Force</b>	71 lbs / 32 kg	<b>Warranty</b>	3 Year
<b>Load Chain Type</b>	G80		

MODEL	PWYAL025	PWYAL050	PWYAL075	PWYAL100	PWYAL150	PWYAL300	PWYAL600	PWYAL900
<b>A</b>	3.1 in / 78.5mm	3.7 in / 95mm	5.8 in / 148mm		6.8 in / 172mm	7.9 in / 200mm		
<b>B</b>	2.4 in / 62mm	2.7 in / 68mm	3.5 in / 90mm		3.9 in / 98mm	4.5 in / 115mm		
<b>C</b>	1.4 in / 36mm	1.7 in / 42mm	1.5 in / 37mm	1.7 in / 45mm	1.9 in / 47mm	2.5 in / 63mm	3.1 in / 78mm	
<b>D</b>	5.9 in / 150mm	8.4 in / 215mm	11 in / 280mm		16.1 in / 410mm			
<b>E</b>	0.8 in / 21mm	0.9 in / 24.5mm	1.1 in / 28mm	1.2 in / 33mm	1.5 in / 33.5mm	1.7 in / 43.5mm	2.0 in / 51mm	2.5 in / 64mm
<b>H</b>	8.3 in / 210mm	10 in / 255mm	12.7 in / 325mm	12.7 in / 325mm	15 in / 380mm	19 in / 480mm	24.5 in / 620mm	27 in / 690mm

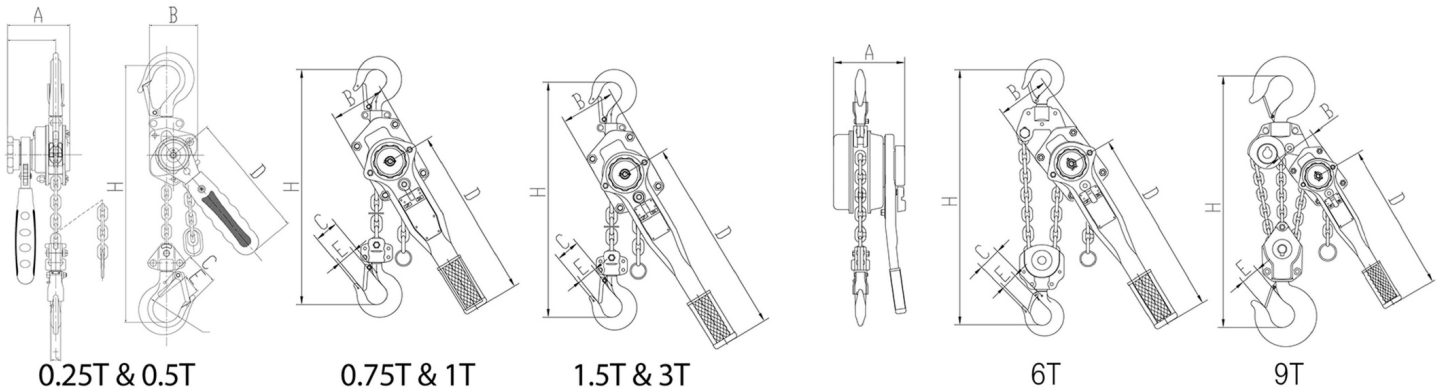

## Unit Weight & Dimensions

**Total Unit Weight**      41 lbs / 19 Kg

## Packaging Weight & Dimensions

**Package 1 Net Weight**      41 lbs / 19 Kg

**Package 1 Width**      7 in / 17.78 cm

**Package 1 Gross Weight**      44 lbs / 20 Kg

**Package 1 Height**      8 in / 20.32 cm

**Package 1 Length**      21 in / 53.34 cm