



## 10 Ton Hydraulic Winch 22000 lbs. EATON Motor

### Key features

- High Capacity: Capable of handling loads up to 10 tons (22,000 lbs) for heavy-duty lifting and pulling.
- Hydraulic Operation: Offers efficient and smooth operation with hydraulic power.
- Enhanced Safety: Includes safety features to protect against overload and ensure secure operation.
- 3 Year Warranty, Customer Support and Service in the USA

### Winch Description

This robust 10 Ton Hydraulic Winch features a powerful 22,000 lbs capacity and is equipped with a high-performance EATON motor. Designed for demanding lifting and pulling tasks, it combines exceptional strength and durability with reliable motor performance for efficient operation in heavy-duty applications.

## Technical Specifications

<b>1st Layer Rated Capacity</b>	22000 lb / 10000 Kg	<b>Wire Rope</b>	ø3/4 in x197 ft   ø18 mm x 60 m
<b>Speed (f/m) / min</b>	23~36 ft / 7~11 m	<b>Standards Compliance</b>	SAE-J706
<b>Number of Speeds</b>	1 Speed	<b>Warranty</b>	3 Year
<b>Motor Type (68)</b>	EATON j2K-160 w/ Counterbalance valve	<b>Oil Pressure</b>	170 bar / 2465 psi
<b>IEC Motor Protection</b>	IP67	<b>Oil Flow</b>	16 gpm / 60.5 l/min

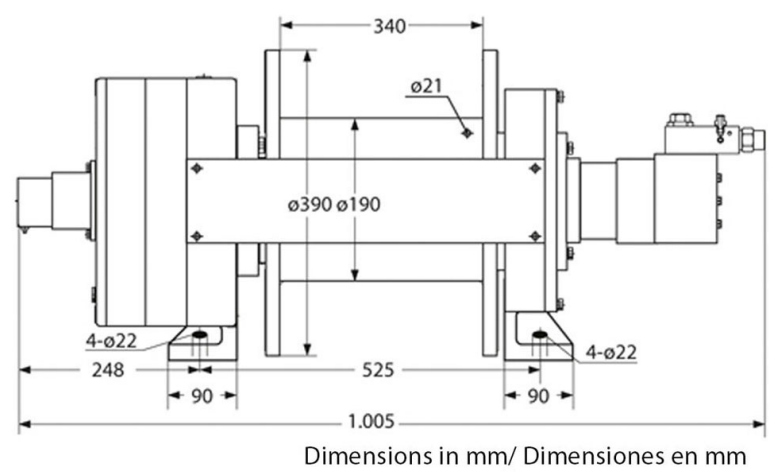
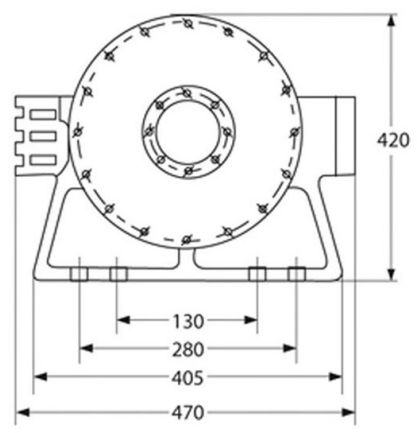

Layers of Rope / Capas del Cable	Line Pull / Capacidad	Speed / Velocidad
1	21854 lb / 9913 kg	23.6 ft / 7.2 m
2	19352 lb / 8778 kg	28 ft / 8.5 m
3	17364 lb / 7876 kg	32 ft / 9.8 m
4	15745 lb / 7142 kg	36.7 ft / 11.2 m

## Unit Weight & Dimensions

<b>A Total Height</b>	420 mm
<b>Drum BD Barrel Diameter (58)</b>	190 mm
<b>D Depth</b>	470 mm
<b>Drum FD Flange Diameter (57)</b>	390 mm
<b>W Width</b>	1005 mm
<b>Drum DL Length (56)</b>	340 mm
<b>Total Unit Weight</b>	760 lbs / 345 Kg

## Packaging Weight & Dimensions

<b>Package 1 Net Weight</b>	760 lbs / 345 Kg
<b>Package 1 Width</b>	22 in / 55.88 cm
<b>Package 1 Gross Weight</b>	793 lbs / 360 Kg
<b>Package 1 Height</b>	23 in / 58.42 cm
<b>Package 1 Length</b>	48 in / 121.92 cm