

## 1100 lb / 2200 lb 220V Electric Rope Hoist w/trolley 60HZ w/ Emergency Stop H1 Duty Wireless

### Key features

- Load Capacity: Available in two capacities—1100 lbs and 2200 lbs—suitable for various lifting needs.
- Voltage: Operates on 220V, compatible with standard industrial electrical systems.
- Wireless Control: Includes a wireless remote control for convenient and flexible operation without being tethered to the hoist.
- 1 Year Warranty, Customer Support and Service in the USA



### Electric Wire Rope Hoist with Power Trolley Description

This **1 ton Electric Wire Rope Hoist with Power Trolley** uses a powerful motor to raise and lower loads up to 38 feet in the air. The single phase power supply makes it ideal home or commercial applications. The hoist is easy to use, and the convenient trolley can be mounted on an I-beam or crane to help you complete large projects with ease.

### Prowinch Electric Wire Rope Hoists with Trolley

All of our electric wire rope hoists are created with the goal of offering the best price-performance ratio. Key components such as lifespan factors are constantly tested and improved in order to offer the best product for the price.

### Key Components

All internal components have been upgraded to meet the highest quality standards. All testing is performed in the US before shipping to ensure that every unit meets the corresponding standard.

### Duty Classification

Duty classification is a key factor when choosing the right unit. This H1 electric wire rope hoist is suitable for infrequent handling, installing and servicing heavy equipment, and idling for long periods between use. For uniformly distributed work periods, the hoist has a 12.5% max. operational time per hour and can handle up to 75 starts per hour. When being used for infrequent work periods, the hoist can be operated for 15 minutes from a cold start with up to 100 starts per hour. Operational time ratings are calculated at a 65% load factor, as per ASME Standards.

### Control System

This electric chain hoist comes standard with a industrial wireless remote control, which is waterproof, shockproof, and can be operated from 100 feet away. It also features a safety key and emergency stop button.

### Braking System

The electromagnetic brake system is tested at 125% of the hoist capacity and is designed to automatically engage immediately upon any loss of power.

## Technical Specifications

<b>Rated Load Capacity</b>	1000Kg @ 2 lines   500Kg @ 1 line	<b>Control</b>	Wireless F21 Remote Control
<b>Standard Lifting Height</b>	40ft single line / 20ft double line (12m / 6m)	<b>Control Voltage</b>	220v Receiver / 2 x AA 1,5v Remote
<b>Speed (f/m) / min</b>	33 ft/10m @1line   16ft/5m @2line	<b>Wire Rope</b>	ø0.22 in   ø5.6 mm
<b>Number of Speeds</b>	1 Speed	<b>Humidity</b>	<85%
<b>Voltage</b>	1 Phase 220~240V 50/60Hz	<b>Temperature</b>	-4°~104° F / -20°~40° C
<b>FCC ID</b>	OFNF21	<b>Noise Level</b>	71 dB
<b>Duty Class</b>	H1/M2/1Cm/Class A	<b>Trolley Speed /min</b>	52 ft/min / 16 m/min
<b>Motor Type (68)</b>	Squirrel Cage Induction Motor	<b>Trolley Number of Speeds</b>	1
<b>Motor Power (6)</b>	1600 W	<b>I-Beam Width Range</b>	3.25 in / 82 mm
<b>Motor AMP</b>	6.5 AMP	<b>Minimum Turn Radius</b>	2.62 ft / .8 m
<b>Motor Brake</b>	YES	<b>Standards Compliance</b>	Intertek 4006091 , CAN/CSA C22.2 , EN14492-2 , EN60204-32
<b>Insulation Grade</b>	B	<b>Warranty</b>	1 Year
<b>IEC Motor Protection</b>	IP54		

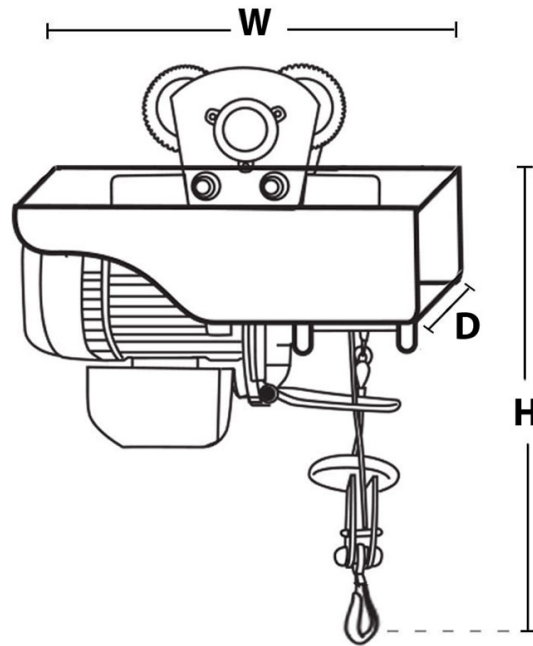

## Unit Weight & Dimensions

<b>H Minimum Headroom</b>	21 in / 535 mm
<b>W Width</b>	18.5 in / 470 mm
<b>D Depth</b>	12.0 in / 305 mm
<b>Total Unit Weight</b>	99 lbs / 45 Kg

## Packaging Weight & Dimensions

<b>Package 1 Net Weight</b>	66 lbs / 30 Kg
<b>Package 2 Net Weight</b>	33 lbs / 15 Kg
<b>Package 1 Gross Weight</b>	75 lbs / 34 Kg
<b>Package 2 Gross Weight</b>	47 lbs / 21 Kg
<b>Package 1 Length</b>	24 in / 60.96 cm
<b>Package 2 Length</b>	15 in / 38.1 cm
<b>Package 1 Width</b>	10 in / 25.4 cm
<b>Package 2 Width</b>	11 in / 27.94 cm
<b>Package 1 Height</b>	24 in / 60.96 cm
<b>Package 2 Height</b>	9 in / 22.86 cm