

1760 lbs. 800Kg Lever Wire Rope Puller Hoist 65 ft wire rope

Key features

- Lifting Capacity: Supports loads up to 1760 lbs (800 kg), making it ideal for moderate lifting and pulling operations.
- Wire Rope Length: Features an extensive 65-foot wire rope, providing ample reach for versatile applications.
- Includes Adjustable Lever and Galvanized Steel Wire Rope with Forged Hook
- Standard ASME/ANSI B30.21
- 3 Year Warranty, Customer Support and Service in the USA



Lever Wire Rope Puller Hoist Description

The 1760 lbs (800 kg) Lever Wire Rope Puller Hoist is a reliable and efficient lifting solution designed for moderate lifting and pulling tasks. With a generous wire rope length of 65 feet, this hoist is perfect for various applications in industrial, commercial, and outdoor settings.

Technical Specifications

Standards Compliance

ASME/ANSI B30.21

Warranty

3 Year

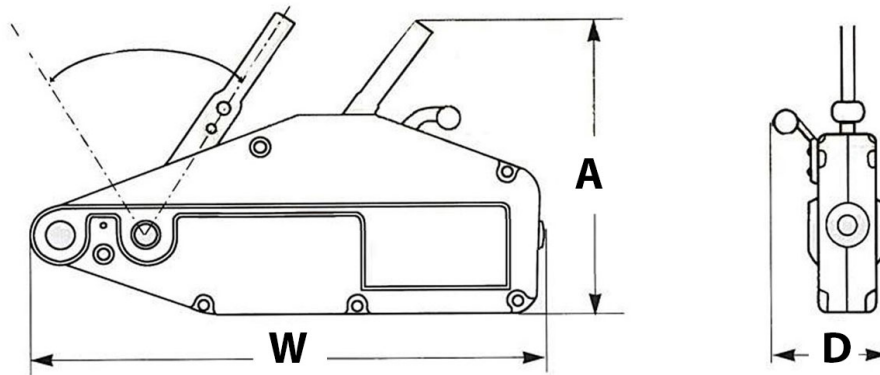

Referential Images
Specifications may change without notice

Unit Weight & Dimensions

A Total Height	235 mm
W Width	426 mm
D Depth	64 mm
Total Unit Weight	39 lbs / 18 Kg

Packaging Weight & Dimensions

Package 1 Net Weight	39 lbs / 18 Kg
Package 1 Width	2 in / 5.08 cm
Package 1 Gross Weight	41 lbs / 19 Kg
Package 1 Height	9 in / 22.86 cm
Package 1 Length	17 in / 43.18 cm