

11880 lb Lever Cable / Wire Rope Puller Hoist 65 ft. Wire Rope

Key features

- **Lifting Capacity:** Supports loads up to 11880 lbs, making it suitable for demanding lifting and pulling operations.
- **Wire Rope Length:** Features a generous 65-foot wire rope, providing extended reach for versatile applications. Built-in Shearing Pin Overload Protection
- Includes Adjustable Lever and Galvanized Steel Wire Rope with Forged Hook
- Standard ASME/ANSI B30.21
- 3 Year Warranty, Customer Support and Service in the USA



Lever Cable / Wire Rope Puller Hoist Description

The 11880 lbs Lever Cable/Wire Rope Puller Hoist is a robust and versatile tool designed for heavy lifting and pulling tasks. With an impressive wire rope length of 65 feet, this hoist is ideal for a variety of applications in industrial, commercial, and outdoor settings.

Technical Specifications

Wire Rope	Ø 0.78 in x 65 ft	Warranty	3 Year
Standards Compliance	ASME/ANSI B30.21		

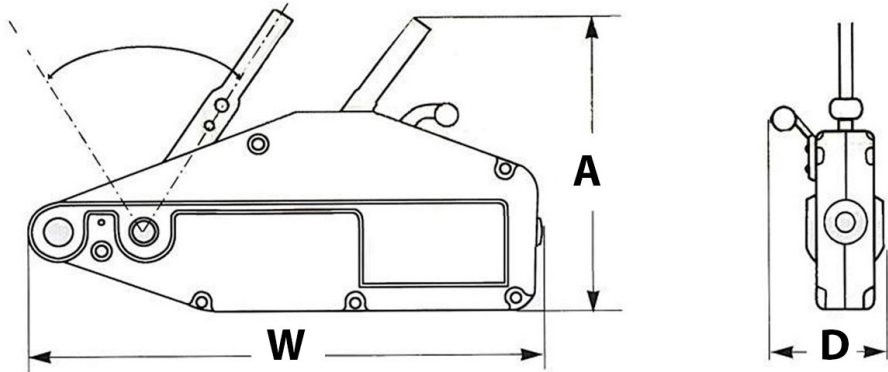

Referential Images
Specifications may change without notice

Unit Weight & Dimensions

A Total Height	480 mm	Package 1 Net Weight	253 lbs / 115 Kg
W Width	930 mm	Package 1 Width	6 in / 15.24 cm
D Depth	152 mm	Package 1 Gross Weight	257 lbs / 117 Kg
Total Unit Weight	253 lbs / 115 Kg	Package 1 Height	17 in / 43.18 cm
		Package 1 Length	37 in / 93.98 cm

Packaging Weight & Dimensions