

11880 lb Lever Wire Rope Puller Hoist 65 ft. Wire Rope

Key features

- Lifting Capacity: Supports loads up to 11880 lbs, making it suitable for the most demanding lifting and pulling operations.
- Wire Rope Length: Features an extensive 65-foot wire rope, providing ample reach for various applications.
- Includes Adjustable Lever and Galvanized Steel Wire Rope with Forged Hook
- Standard ASME/ANSI B30.21
- 3 Year Warranty, Customer Support and Service in the USA



Lever Wire Rope Puller Hoist Description

The 11880 lbs Lever Wire Rope Puller Hoist is a powerful and efficient lifting tool designed for heavy-duty applications. With a generous wire rope length of 65 feet, this hoist is ideal for a wide range of lifting and pulling tasks in various industrial and commercial settings.

Technical Specifications

Standards Compliance

ASME/ANSI B30.21

Warranty

3 Year

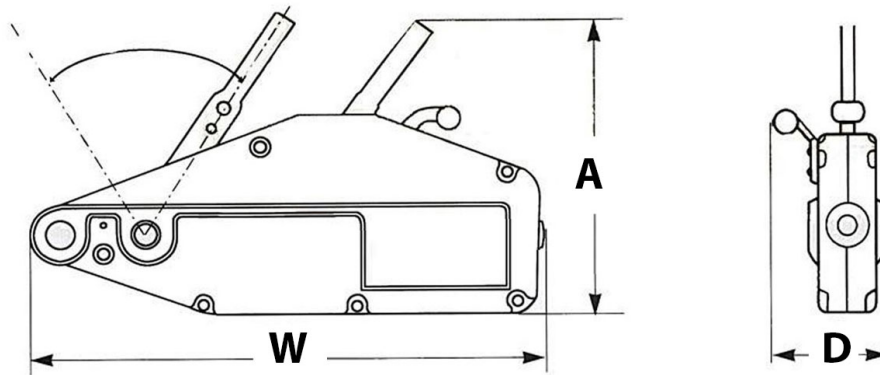

Referential Images
Specifications may change without notice

Unit Weight & Dimensions

A Total Height	480 mm
W Width	930 mm
D Depth	152 mm
Total Unit Weight	216 lbs / 99 Kg

Packaging Weight & Dimensions

Package 1 Net Weight	216 lbs / 98 Kg
Package 1 Width	21 in / 53.34 cm
Package 1 Gross Weight	218 lbs / 99 Kg
Package 1 Height	12 in / 30.48 cm
Package 1 Length	37 in / 93.98 cm