



## 1/2 Ton Manual Winch Automatic Brake

### Key features

- Load Capacity: Capable of lifting or pulling up to 1/2 ton (1,000 lbs), suitable for moderate-duty tasks.
- Automatic Brake: Features an automatic brake system to securely hold the load and prevent slippage.
- Manual Operation: Operates manually, ideal for use in locations without power sources.
- 1 Year Warranty, Customer Support and Service in the USA

### Winch Description

This manual winch offers a 1/2-ton capacity and comes with an automatic brake for enhanced safety and control. Engineered for dependable performance, it provides smooth and secure operation for a range of lifting and pulling tasks.

## Technical Specifications

<b>1st Layer Rated Capacity</b>	1102 lb / 500 kg	<b>Recommended Wire Rope</b>	ø1/4 in x 82 ft   ø6.8 mm x 25 m
<b>Number of Speeds</b>	1 Speed	<b>Standards Compliance</b>	ASMEB30.7
<b>Motor Type (68)</b>	Manual Crank	<b>Warranty</b>	1 Year
<b>Drum Brake</b>	Automatic		

Dimensions in mm / Dimensiones en mm

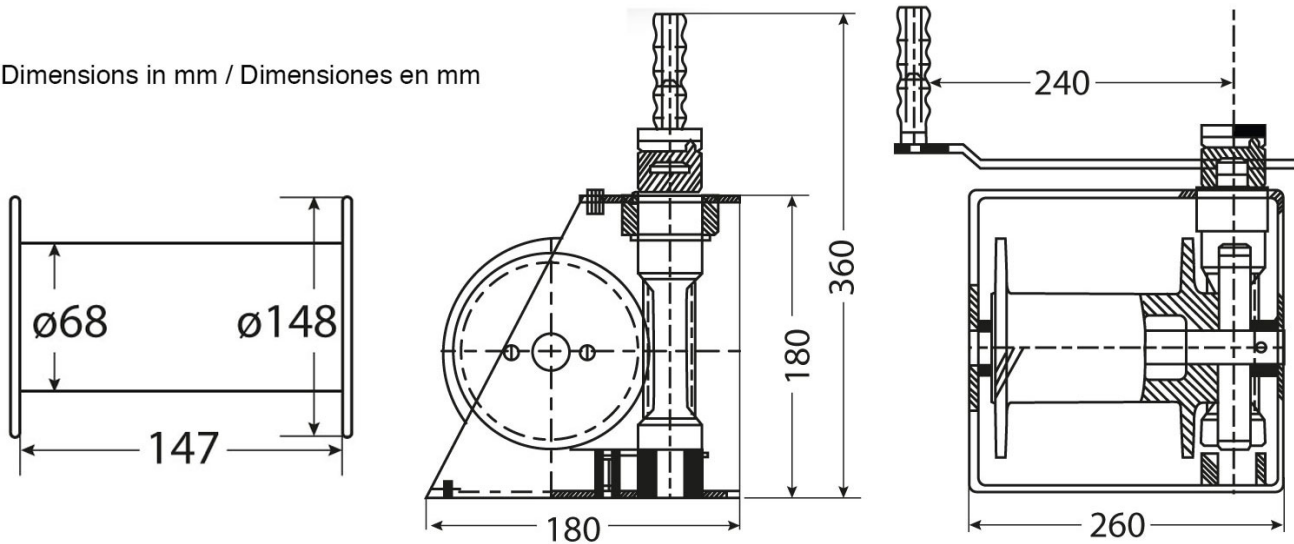

Imágenes Referenciales  
Image Reference

## Unit Weight & Dimensions

<b>Total Unit Weight</b>	35 lbs / 16 Kg
--------------------------	----------------

## Packaging Weight & Dimensions

<b>Package 1 Net Weight</b>	35 lbs / 16 Kg
<b>Package 1 Width</b>	11 in / 27.94 cm
<b>Package 1 Gross Weight</b>	37 lbs / 17 Kg
<b>Package 1 Height</b>	9 in / 22.86 cm
<b>Package 1 Length</b>	12 in / 30.48 cm