



1/4 Ton Manual Winch Automatic Brake

Key features

- Load Capacity: Capable of lifting or pulling up to 1/4 ton (500 lbs), suitable for lighter-duty tasks.
- Automatic Brake: Features an automatic brake system to securely hold the load and prevent slippage.
- Manual Operation: Operates manually, ideal for use where power sources are not available.
- 1 Year Warranty, Customer Support and Service in the USA

Winch Description

This manual winch supports a 1/4-ton capacity and features an automatic brake for added safety and control. Designed for reliable performance, it ensures smooth and secure handling of lighter loads in various lifting and pulling applications.

Technical Specifications

1st Layer Rated Capacity	551 lb / 250 kg	Drum Brake	Automatic
Number of Speeds	1 Speed	Recommended Wire Rope	ø1/4 in x 65 ft ø 5 mm x 20 m
Motor Type (68)	Manual Crank	Standards Compliance	ASMEB30.7
Gear Ratio	15:1	Warranty	1 Year

Dimensions in mm / Dimensiones en mm

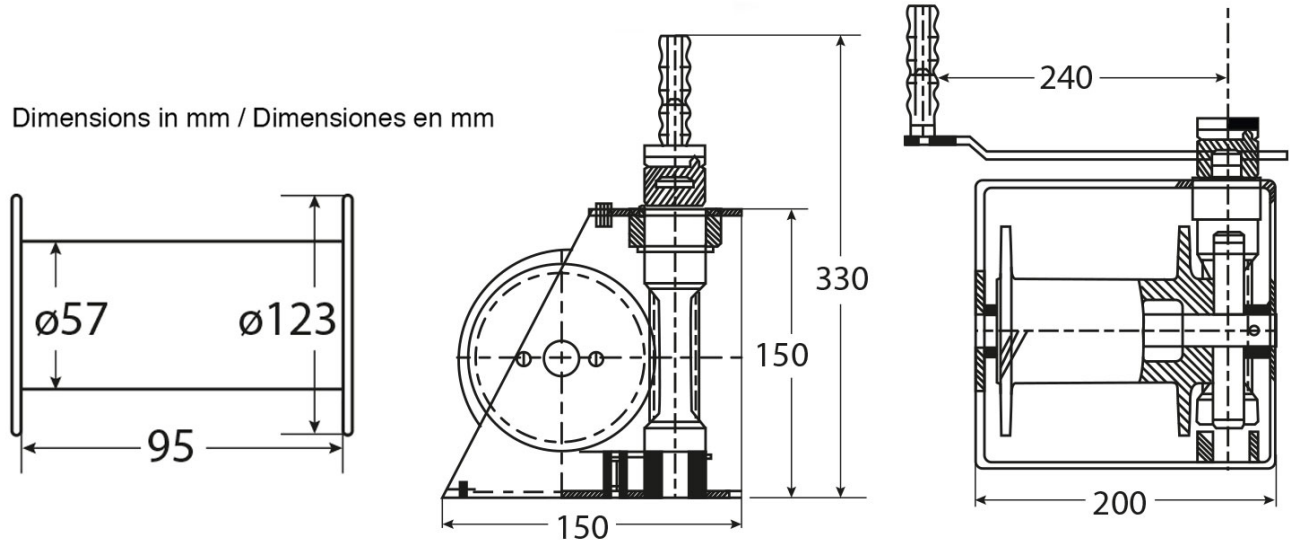

Imágenes Referenciales
Image Reference

Unit Weight & Dimensions

Total Unit Weight	24 lbs / 11 Kg
--------------------------	----------------

Packaging Weight & Dimensions

Package 1 Net Weight	24 lbs / 11 Kg
Package 1 Width	9 in / 22.86 cm
Package 1 Gross Weight	26 lbs / 12 Kg
Package 1 Height	7 in / 17.78 cm
Package 1 Length	9 in / 22.86 cm