



1 Ton Manual Winch Automatic Brake

Key features

- Load Capacity: Capable of lifting or pulling up to 1 ton (2,000 lbs), suitable for heavy-duty tasks.
- Automatic Brake: Features an automatic brake system to securely hold the load and prevent slippage.
- Manual Operation: Operates manually, ideal for use in locations without access to power sources.
- 1 Year Warranty, Customer Support and Service in the USA

Winch Description

This manual winch supports a 1-ton capacity and features an automatic brake for enhanced safety and control. Built for reliability and ease of use, it ensures secure and smooth operation for various lifting and pulling tasks.

Technical Specifications

1st Layer Rated Capacity	2204 lb / 1000 kg	Drum Brake	Automatic
Number of Speeds	1 Speed	Recommended Wire Rope	ø3/8 in x 114 ft ø9 mm x 35 m
Motor Type (68)	Manual Crank	Standards Compliance	ASMEB30.7
Gear Ratio	26:1	Warranty	1 Year

Dimensions in mm / Dimensiones en mm

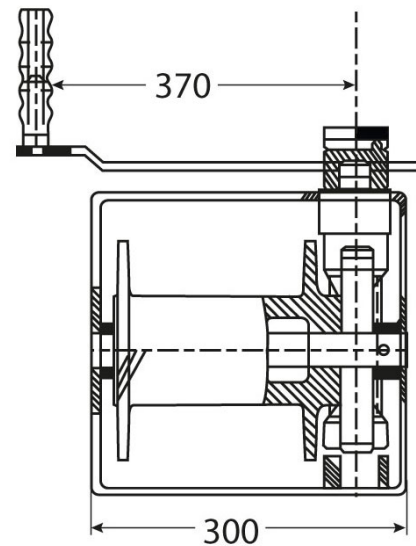
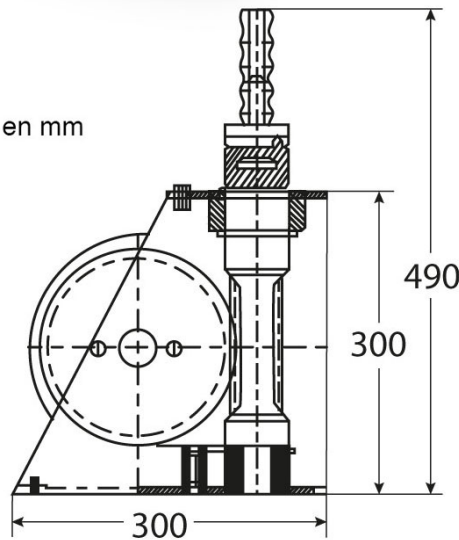
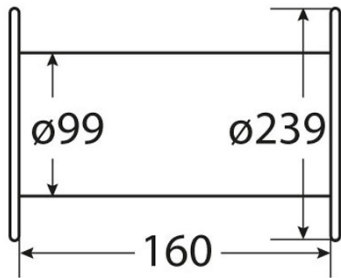

Imágenes Referenciales
Image Reference

Unit Weight & Dimensions

Total Unit Weight	66 lbs / 30 Kg
--------------------------	----------------

Packaging Weight & Dimensions

Package 1 Net Weight	66 lbs / 30 Kg
Package 1 Width	12 in / 30.48 cm
Package 1 Gross Weight	70 lbs / 32 Kg
Package 1 Height	12 in / 30.48 cm
Package 1 Length	16 in / 40.64 cm