



22000 lbs. 10 tons 10 ft Manual Chain Hoist G80 Black Tempered Chain

Key features

- Reliable Double Pawl Brake System with Dust Cover Protection
- Grade 80 (TH) Load Chain
- Standard ASME/ANSI B30.16 , ISO 16877-2008
- 3 Year Warranty, Customer Support and Service in the USA

Manual Chain Hoist Description

The **Prowinch 10 Ton Manual Chain Hoist** offers a heavy duty lifting solution, even in places where electricity may not be available. The hook allows it to be installed wherever it is needed. The hoist is perfect for home or industrial applications.

Prowinch Manual Chain Hoist

All of our **Manual Chain Hoists** are created with the goal of offering the best price-performance ratio. Key components such as lifespan factors are constantly tested and improved in order to offer the best product for the price.

Braking System

The reliable double pawl brake system is tested at 125% of the hoist capacity.

Technical Specifications

Rated Load Capacity	22050 lb / 10000 kg	Load Chain Size	10x30 mm
Standard Lifting Height	10 ft / 3 m	Standards Compliance	ANSI/ASME B30.16, EN13157, ISO 16877-2008
Capacity Range	8	Warranty	3 Year
Load Chain Type	G80		

Model/Modelo	PWTB050	PWTB100	PWTB150	PWTB200	PWTB300	PWTB500	PWTB1000	PWTB2000
A	4.9 in / 124 mm	5.3 in / 134 mm	5.9 in / 149 mm	6.2 in / 157 mm		7.1 in / 180 mm		8.9 in / 226 mm
B	5.1 in / 129 mm	6.1 in / 154 mm	6.8 in / 172 mm	7.3 in / 185.42 mm	9.3 in / 236 mm	10.3 in / 261 mm	14.4 in / 365 mm	21.7 in / 551 mm
C	1.7 in / 43 mm	2.0 in / 50 mm	2.5 in / 63.5 mm		3.9 in / 99 mm	5.0 in / 127 mm	10.2 in / 259 mm	11.3 in / 287 mm
D	1.0 in / 25 mm	1.2 in / 30 mm	1.3 in / 33 mm		2.2 in / 55 mm	2.9 in / 73 mm	3.9 in / 99 mm	4.8 in / 121 mm
E	1.1 in / 27 mm	1.3 in / 33 mm		1.5 in / 38 mm	1.7 in / 43 mm	2.0 in / 50 mm	2.5 in / 63 mm	3.2 in / 81 mm
F	1.3 in / 33 mm	1.6 in / 40 mm	1.7 in / 43 mm	1.8 in / 45 mm	2.0 in / 50 mm	2.4 in / 60 mm	3.3 in / 83 mm	4.3 in / 109 mm
G	1.4 in / 35 mm	1.8 in / 45 mm	1.9 in / 48 mm	2.0 in / 50 mm	2.5 in / 63 mm	3.1 in / 78 mm		

0.5 t, 1 t, 1.5 t & 2 t

3 t & 5 t

10 t

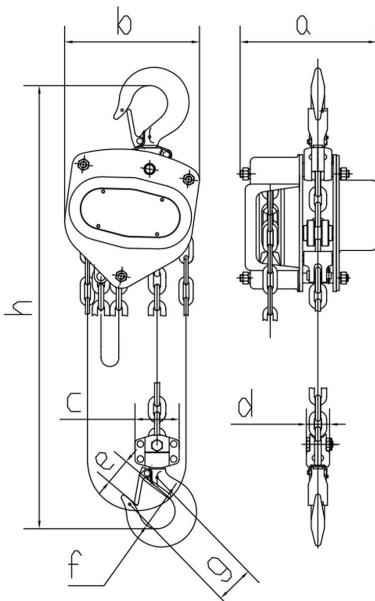

15 t

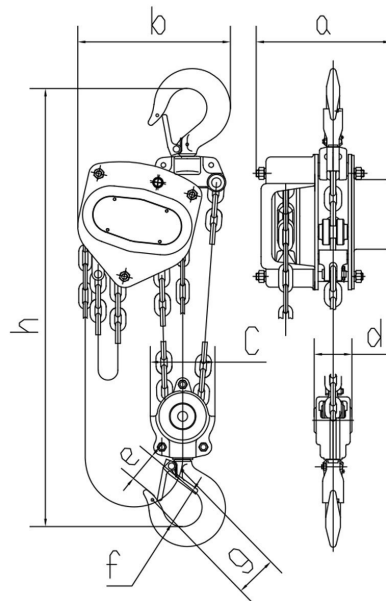

20 t

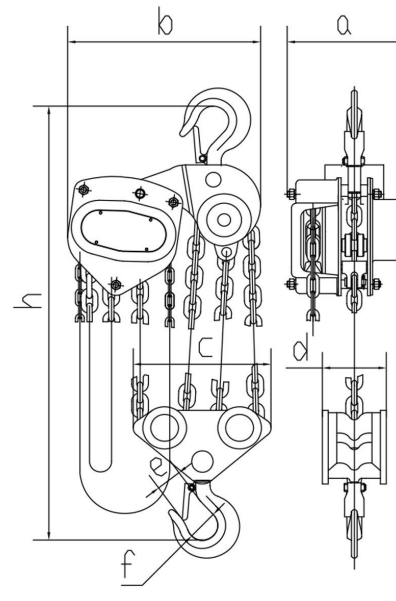

30 t

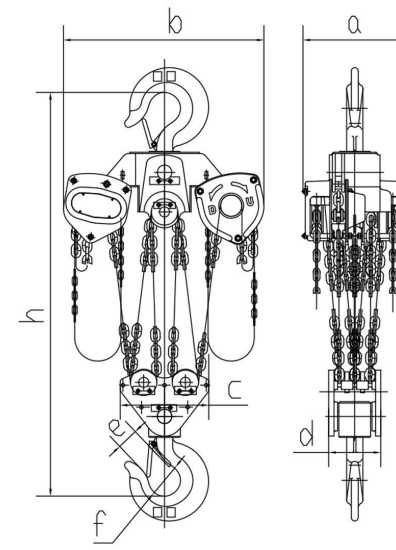
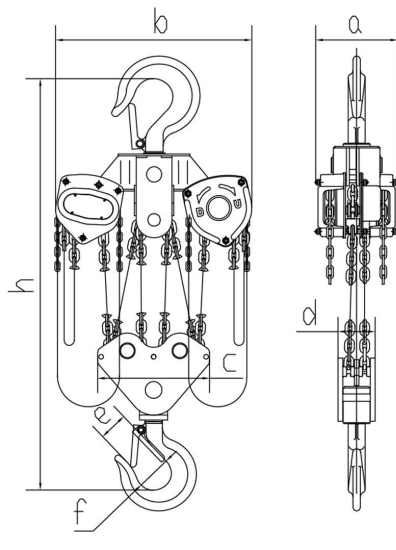
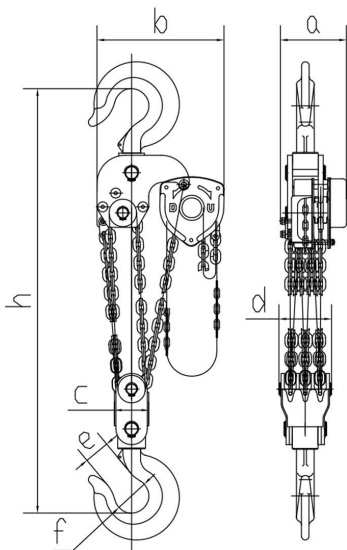

Unit Weight & Dimensions

H Minimum Headroom	2.5 ft / 0.7 m
Total Unit Weight	198 lbs / 90 Kg

Packaging Weight & Dimensions

Package 1 Net Weight	198 lbs / 90 Kg
Package 1 Width	16 in / 40.64 cm
Package 1 Gross Weight	213 lbs / 97 Kg
Package 1 Height	7 in / 17.78 cm
Package 1 Length	22 in / 55.88 cm