



Directional Hydraulic Control Valve PWSH45

Key features

- Directional Control: Precisely directs hydraulic fluid flow to various functions and components.
- Heavy-Duty Construction: Built to withstand high-pressure applications and rugged environments.
- Versatile Functionality: Suitable for various hydraulic machinery and equipment.
- 3 Year Warranty, Customer Support and Service in the USA

Directional Hydraulic Control Valve PWSH45 Description

The PWSH45 Directional Hydraulic Control Valve is engineered for precise control in hydraulic systems. Designed for versatility and reliability, it allows for smooth directional changes and efficient operation in various applications. Ideal for use in hydraulic winches, machinery, and equipment requiring accurate fluid flow management.

Technical Specifications

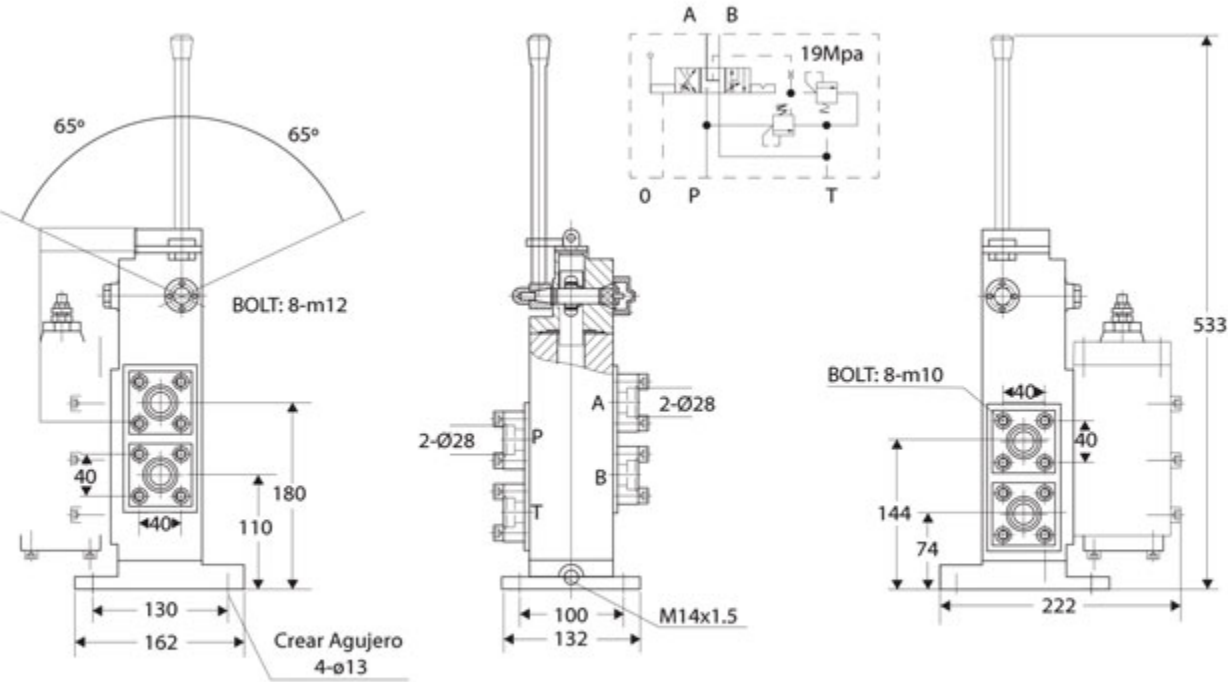

Dimensions in mm / Dimensiones en mm