



7.5 ton Electric Chain Hoist w/ Power Trolley Variable Speed 380V 3ø 50~60HZ 30ft G100 Nickel Duty H4/M5

Key features

- Load Capacity: Handles up to 7.5 tons (16,500 lbs.), suitable for heavy-duty lifting tasks.
- Variable Speed: Features variable speed control for precise and adjustable lifting and movement.
- Variable Speed: Features variable speed control for precise and adjustable lifting and movement.
- 3 Year Warranty, Customer Support and Service in the USA

Electric Chain Hoist Description

This 7.5-ton electric chain hoist features a power trolley with variable speed control for precise lifting and smooth horizontal movement. Operating on a 380V 3-phase 50~60Hz power supply, it comes equipped with a 30ft G100 nickel-duty chain, ensuring high durability and performance for demanding industrial tasks. Rated H4/M5 for heavy-duty use.

Technical Specifications

| | | | |
|------------------------------------|--|---------------------------------|--|
| Rated Load Capacity | 7.5 ton | Load Chain Type | G100 Nikel |
| Standard Lifting Height | 30 ft / 9 m | Load Chain Size | 11.2 mm |
| Speed (f/m) / min | ft @60Hz 0.3~1.8 mt @50Hz | Chain Falls | 3 |
| Number of Speeds | Variable Speed | Chain Length | 90 ft (27 m) |
| Voltage | 3 Phase 380V 50Hz | Humidity | 20%~90% |
| Total Power Watts | 4000 | Temperature | -4 ~ 104° F / -20 ~ 40° C |
| Duty Class | H4/M5/2m/Class D | Trolley Power | 750 |
| IEC Motor Protection | IP55 | Trolley Speed /min | 5.9~47.23 ft @60Hz 1.5~12 mt @50Hz |
| Control | Pendant Control IP66 and Optional Wireless | Trolley Number of Speeds | Variable |
| Control Voltage | 24V | Standards Compliance | ASME HST-1 , ASME B30.16 , B30.17 , EN60204-37 |
| Emergency Stop | Yes | Warranty | 3 Year |
| Transmission / Reducer Type | Spur gearbox | | |

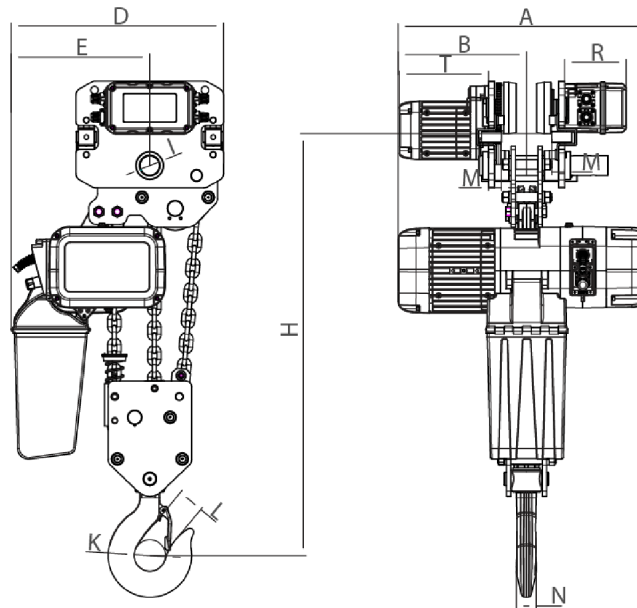

| Rated load (t) | Type | Dimension (mm) | | | | | | | | | | | | |
|----------------|-----------|---|-----|-----------|-----|-----|-----|----|----|----|----|----|-----|-----|
| | | Minimum distance from the bottom of the track to the bottom hook: H | A | L | B | D | E | I | M | N | K | L | T | R |
| 7 | PWRXT7-03 | 1020 | 681 | 3500-5500 | 350 | 579 | 375 | 54 | 35 | 48 | 85 | 80 | 242 | 167 |

Unit Weight & Dimensions

| | |
|--|------|
| H Minimum Headroom | 1170 |
| W Width | 576 |
| A Total Height | 1020 |
| J Hook Opening | 85 |
| D Depth | 681 |
| Total Weight (w/out cable or Chain) | 130 |

Packaging Weight & Dimensions

| | |
|-------------------------------|--------------------|
| Package 1 Net Weight | 294.8 lbs / 134 Kg |
| Package 2 Net Weight | 345.4 lbs / 157 Kg |
| Package 1 Gross Weight | 495 lbs / 225 Kg |
| Package 2 Gross Weight | 374 lbs / 170 Kg |
| Package 1 Length | 30 in / 76.2 cm |
| Package 2 Length | 11 in / 27.94 cm |

| | | | |
|--------------------------|--------------------|-------------------------|------------------|
| Total Unit Weight | 640.2 lbs / 291 Kg | Package 1 Width | 20 in / 50.8 cm |
| | | Package 2 Width | 14 in / 35.56 cm |
| | | Package 1 Height | 31 in / 78.74 cm |
| | | Package 2 Height | 23 in / 58.42 cm |