



5 ton Electric Chain Hoist w/ Power Trolley Variable Speed 380V 3Ø 50~60HZ 30ft G100 Nickel Duty H4/M5

Key features

- Load Capacity: Capable of lifting up to 5 tons (11,000 lbs.), suitable for heavy-duty lifting applications.
- Voltage and Frequency: Operates on a 380V, 3-phase electrical system with a frequency range of 50~60Hz, fitting various industrial power setups.
- Variable Speed: Features variable speed control for precise and flexible lifting and movement adjustments.
- 3 Year Warranty, Customer Support and Service in the USA

Electric Chain Hoist Description

This 5-ton electric chain hoist features a power trolley with variable speed control for precise lifting and smooth horizontal movement. It operates on a 380V 3-phase 50~60Hz power supply, providing versatile and reliable performance for various industrial lifting applications.

Technical Specifications

Rated Load Capacity	5 ton	Load Chain Type	G100 Nikel
Standard Lifting Height	30 ft / 9 m	Load Chain Size	11.2 mm
Speed (f/m) / min	ft @60Hz 0.4~2.7 mt @50Hz	Chain Falls	2
Number of Speeds	Variable Speed	Chain Length	60 ft (18 m)
Voltage	3 Phase 380V 50Hz	Humidity	20%~90%
Total Power Watts	4000	Temperature	-4 ~ 104° F / -20 ~ 40° C
Duty Class	H4/M5/2m/Class D	Trolley Power	750
IEC Motor Protection	IP55	Trolley Speed /min	5.9~47.23 ft @60Hz 1.5~12 mt @50Hz
Control	Pendant Control IP66 and Optional Wireless	Trolley Number of Speeds	Variable
Control Voltage	24V	Standards Compliance	ASME HST-1 , ASME B30.16 , B30.17 , EN60204-36
Emergency Stop	Yes	Warranty	3 Year
Transmission / Reducer Type	Spur gearbox		

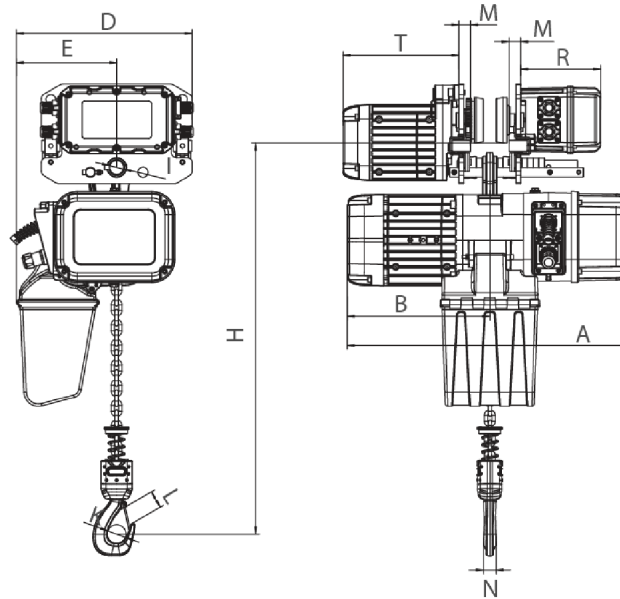

Rated load (t)	Type	Dimension (mm)												
		Minimum distance from the bottom of the track to the bottom hook: H	A	L	B	D	E	I	M	N	K	L	T	R
1	PWRXT1-01	473	440	3500-5500	285	210	20	105	140					
2	PWRXT2-01	516	590		276	368	210	31	24	25	42	32	242	167
3	PWRXT3-01	600	681		350	422	264	36	28	35	52	42	242	167
5	PWRXT5-02	645	681		350	478	307	43	30	34	59	48	242	167

Unit Weight & Dimensions

H Minimum Headroom	810
W Width	500

Packaging Weight & Dimensions

Package 1 Net Weight	294.8 lbs / 134 Kg
Package 2 Net Weight	172.7 lbs / 78 Kg

A Total Height	810	Package 1 Gross Weight	495 lbs / 225 Kg
J Hook Opening	60	Package 2 Gross Weight	187 lbs / 85 Kg
D Depth	681	Package 1 Length	30 in / 76.2 cm
Total Weight (w/out cable or Chain)	185	Package 2 Length	11 in / 27.94 cm
Total Unit Weight	467.5 lbs / 213 Kg	Package 1 Width	20 in / 50.8 cm
		Package 2 Width	14 in / 35.56 cm
		Package 1 Height	31 in / 78.74 cm
		Package 2 Height	23 in / 58.42 cm