



5 ton Electric Chain Hoist w/ Power Trolley 2 Speed 575V 3ø 50/60HZ 30ft G100 Nickel Duty H4/M5

Key features

- Lifting Capacity: 5 tons (10,000 lbs)
- Power Supply: 575V, 3-phase, 50/60Hz
- Speed Options: Two-speed operation for improved control and accuracy
- 3 Year Warranty, Customer Support and Service in the USA

Electric Chain Hoist Description

The 5 Ton Electric Chain Hoist with Power Trolley and two-speed functionality is engineered for efficient lifting and transport in industrial applications. With a lifting capacity of 5 tons, this hoist operates on 575V, 3-phase, 50/60Hz power, making it suitable for a wide range of operational environments. The integrated power trolley ensures smooth horizontal movement, while the two-speed operation allows for enhanced control and precision during lifting tasks. Built for durability and equipped with essential safety features, this hoist is perfect for demanding work conditions.

Our Dedication to Excellence:

At Prowinch, our unwavering commitment to delivering the best price-performance ratio is evident in every Electric Chain Hoist we produce. We subject each unit to meticulous testing and continuously enhance key components, considering factors that influence lifespan. This commitment ensures that we consistently provide a superior product at an optimal price point.

Enhanced Components:

Internally, each component has undergone substantial upgrades to meet the highest quality standards. Key electronic parts are carefully sourced from reputable brands, while locally manufactured lubricants are employed to fortify the durability of gears and reducers. The final assembly and testing processes take place in the US, guaranteeing that every unit surpasses corresponding standards.

Double Speed Precision:

Our Double Speed Electric Chain Hoist is engineered for versatility in lifting operations. Offering both high and low-speed options, this hoist provides precision and adaptability, making it suitable for a wide range of applications.

Duty Classification:

Choosing the right unit is pivotal, and our M5-rated H4 hoists stand out for their excellence in high-volume handling. Tailored for environments like steel warehouses, machine shops, fabricating plants, and mills, these hoists boast a 50% maximum operational time per hour for uniformly distributed work periods. They can efficiently handle up to 300 starts per hour. In scenarios of infrequent work periods, the hoist can operate for 30 minutes from a cold start with up to 300 starts per hour. Operational time ratings adhere to a 65% load factor, following ASME HST-1-2012 guidelines.

Control System:

The Double Speed Electric Chain Hoist features an advanced control system, providing flexibility with both high and low-speed options. The standard pendant control, designed with a length 4 feet less than the lifting height, ensures easy operation from ground level. For added convenience, an optional wireless control is available.

Advanced Braking System:

Our hoists feature an electromagnetic brake system, rigorously tested at 125% of the hoist capacity. This system is intelligently designed to engage automatically upon any loss of power, ensuring not only enhanced safety but also precise control over the operation of the hoist.

Technical Specifications

Rated Load Capacity	5 ton	Chain Length	60
Standard Lifting Height	30 ft / 9 m	Humidity	20%~90%
Speed (f/m) / min	3.1/10.6 ft @60Hz 0.8/2.7 mt @50Hz	Temperature	-4 ~ 104° F / -20 ~ 40° C
Number of Speeds	2 Speed	Minimum Turn Radius	1.8
Voltage	3 Phase 575v 50/60 Hz	Standards Compliance	ASME HST-1 , ASME B30.16 , B30.17 , EN60204-36
Total Power Watts	3750	Warranty	3 Year
Duty Class	H4/M5/2m/Class D	Hoist Motor Power in KW	3
IEC Motor Protection	IP55	Hour Meter	Internal Working Hour Meter
Control	Pendant Control IP66 and Optional Wireless	Hoist Motor Insulation Grade	F
Control Voltage	24V	Hoist Contactor Coil Voltage	24 V
Emergency Stop	Yes	Hoist Contactors Amps	25A
Transmission / Reducer Type	Spur gearbox	Hoist Contactor Brand	Schneider
Load Chain Type	G100 Nickel	IEC Hoist IP Protection	IP55
Load Chain Size	11.2 mm	IEC Pendant Control Protection	IP66
Chain Falls	2	Hoist Motor Brake Type and DC Voltage	DC260V

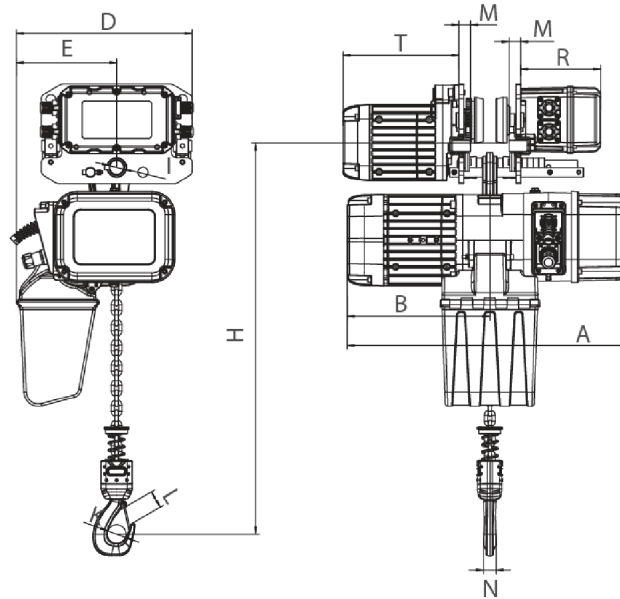

Rated load (t)	Type	Dimension (mm)												
		Minimum distance from the bottom of the track to the bottom hook: H	A	L	B	D	E	I	M	N	K	L	T	R
1	PWRXT1-01	473	440	3500-5500	285	210	20	105	140					
2	PWRXT2-01	516	590		276	368	210	31	24	25	42	32	242	167
3	PWRXT3-01	600	681		350	422	264	36	28	35	52	42	242	167
5	PWRXT5-02	645	681		350	478	307	43	30	34	59	48	242	167

Unit Weight & Dimensions

H Minimum Headroom	810
J Hook Opening	60

Packaging Weight & Dimensions

Package 1 Net Weight	294.8 lbs / 134 Kg
Package 2 Net Weight	172.7 lbs / 78 Kg

A Total Height	810	Package 1 Gross Weight	495 lbs / 225 Kg
Total Weight (w/out cable or Chain)	185	Package 2 Gross Weight	187 lbs / 85 Kg
D Depth	681	Package 1 Length	30 in / 76.2 cm
1st Package Type	Wood Crate	Package 2 Length	11 in / 27.94 cm
W Width	500	Package 1 Width	20 in / 50.8 cm
2nd Package Type	Wood Crate	Package 2 Width	14 in / 35.56 cm
Total Unit Weight	467.5 lbs / 213 Kg	Package 1 Height	31 in / 78.74 cm
		Package 2 Height	23 in / 58.42 cm