



3 ton Electric Chain Hoist w/ Power Trolley Variable Speed 110V 1ø 60HZ 30ft G100 Nickel Duty H4/M5

Key features

- Capacity: Lifts up to 3 tons (approximately 6,000 lbs)
- Power Supply: 110V single-phase, 60Hz for easy compatibility
- Speed Control: Variable speed operation for accurate lifting and lowering
- 3 Year Warranty, Customer Support and Service in the USA

Electric Chain Hoist Description

The 3 Ton Electric Chain Hoist with Power Trolley is a high-capacity lifting solution designed for demanding applications. Featuring variable speed control, this hoist allows for precise handling of loads up to 6,000 lbs. Operating on a 110V single-phase 60Hz power supply, it is versatile for various environments. The integrated power trolley ensures smooth horizontal movement, making it ideal for tasks that require flexibility and accuracy.

Technical Specifications

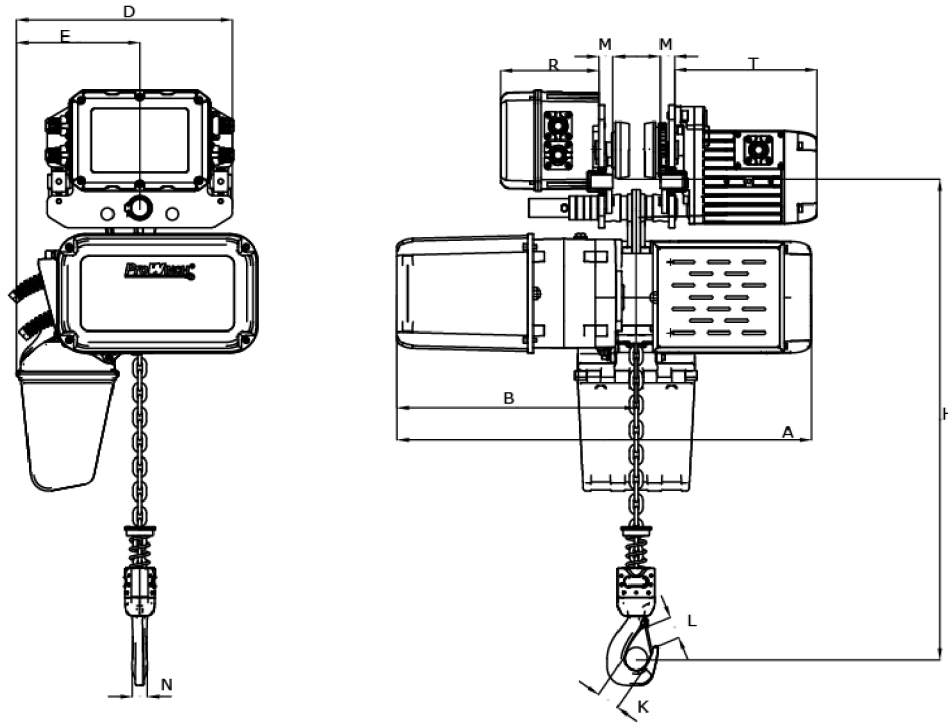

Rated load (t)	Type	Dimension (mm)												
		Minimum distance from the bottom of the track to the bottom hook: H	A	L	B	D	E	I	M	N	K	L	T	R
1	PWRXT1-VS-110V	516	704.5	3500-5500	406.5	368	210	31	24	25	42	32	242	167
2-3	PWRXT2-3-VS-110V	640	780		348	463	263	45	20	35	52	42	242	167

Unit Weight & Dimensions

Total Unit Weight

295.9 lbs / 135 Kg