



3 ton Electric Chain Hoist w/ Power Trolley Variable Speed 440~480V 3ø 50~60HZ 30ft G100 Nickel Duty H4/M5

Key features

- Load Capacity: Lifts up to 3 tons (6,600 lbs.), suitable for medium-duty industrial applications.
- Voltage and Frequency: Operates on 40~480V , 3-phase electrical systems with a frequency of 50-60Hz, accommodating different industrial power setups.
- Variable Speed: Features variable speed control for precise lifting and movement adjustments.
- 3 Year Warranty, Customer Support and Service in the USA

Electric Chain Hoist Description

This 3-ton electric chain hoist features a power trolley with variable speed control for precise lifting and smooth horizontal movement. It operates on a 440~480V 3-phase 50-60Hz power supply, delivering adaptable and efficient performance for various industrial applications.

Our Dedication to Excellence:

At Prowinch, our unwavering commitment to delivering the best price-performance ratio is evident in every Electric Chain Hoist we produce. We subject each unit to meticulous testing and continuously enhance key components, considering factors that influence lifespan. This commitment ensures that we consistently provide a superior product at an optimal price point.

Enhanced Components:

Internally, each component has undergone substantial upgrades to meet the highest quality standards. Key electronic parts are carefully sourced from reputable brands, while locally manufactured lubricants are employed to fortify the durability of gears and reducers. The final assembly and testing processes take place in the US, guaranteeing that every unit surpasses corresponding standards.

Variable Speed Innovation:

Designed for unparalleled control, our Variable Speed Electric Chain Hoist offers a dynamic lifting experience. Ideal for applications requiring precise load positioning, this hoist allows you to adjust lifting speeds according to the specific needs of your project.

Duty Classification:

Choosing the right unit is pivotal, and our M5-rated H4 hoists stand out for their excellence in high-volume handling. Tailored for environments like steel warehouses, machine shops, fabricating plants, and mills, these hoists boast a 50% maximum operational time per hour for uniformly distributed work periods. They can efficiently handle up to 300 starts per hour. In scenarios of infrequent work periods, the hoist can operate for 30 minutes from a cold start with up to 300 starts per hour. Operational time ratings adhere to a 65% load factor, following ASME HST-1-2012 guidelines.

Control System:

The Variable Speed Electric Chain Hoist is equipped with an advanced control system, allowing for precise speed adjustments tailored to your lifting requirements. The standard pendant control, designed with a length 4 feet less than the lifting height, ensures easy operation from ground level. For added convenience, an optional wireless control is available.

Advanced Braking System:

Our hoists feature an electromagnetic brake system, rigorously tested at 125% of the hoist capacity. This system is intelligently designed to engage automatically upon any loss of power, ensuring not only enhanced safety but also precise control over the operation of the hoist.

Technical Specifications

Rated Load Capacity	3 ton	Load Chain Type	G100 Nickel
Standard Lifting Height	30 ft / 9 m	Load Chain Size	11.2 mm
Speed (f/m) / min	2.7~21.2 ft @60Hz mt @50Hz	Chain Falls	1
Number of Speeds	Variable Speed	Chain Length	30
Voltage	3 Phase 440~480V 60Hz	Humidity	20%~90%
Total Power Watts	4000	Temperature	-4 ~ 104° F / -20 ~ 40° C
Duty Class	H4/M5/2m/Class D	Trolley Power	500
IEC Motor Protection	IP55	Trolley Speed /min	5.9~47.23 ft @60Hz 1.5~12 mt @50Hz
Control	Pendant Control IP66 and Optional Wireless	Trolley Number of Speeds	Variable
Control Voltage	24V	Standards Compliance	ASME HST-1 , ASME B30.16 , B30.17 , EN60204-35
Emergency Stop	Yes	Warranty	3 Year
Transmission / Reducer Type	Spur gearbox		

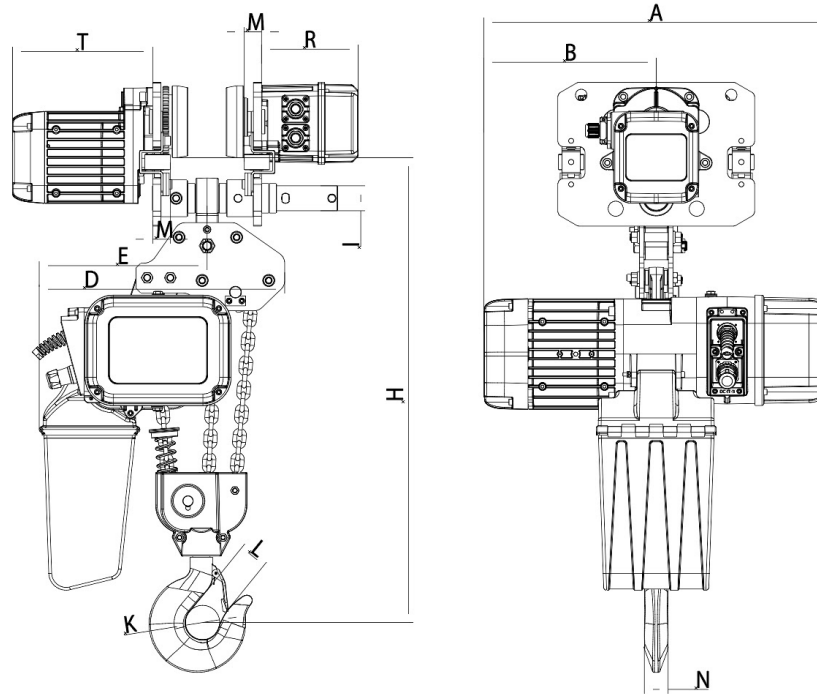

H	A	B	D	E	I	M	N	K	L	T	R
645	590	276	425	290	43	30	34	59	48	242	167

Unit Weight & Dimensions

H Minimum Headroom	645
W Width	350
A Total Height	645
J Hook Opening	59
D Depth	681
Total Weight (w/out cable or Chain)	130
Total Unit Weight	295.9 lbs / 135 Kg

Packaging Weight & Dimensions

Package 1 Net Weight	184.8 lbs / 84 Kg
Package 2 Net Weight	111.1 lbs / 50 Kg
Package 1 Gross Weight	330 lbs / 150 Kg
Package 2 Gross Weight	121 lbs / 55 Kg
Package 1 Length	30 in / 76.2 cm
Package 2 Length	11 in / 27.94 cm
Package 1 Width	20 in / 50.8 cm
Package 2 Width	14 in / 35.56 cm
Package 1 Height	31 in / 78.74 cm
Package 2 Height	23 in / 58.42 cm