



3 ton Electric Chain Hoist w/ Power Trolley 1 Speed 380V 3ø 50HZ 30ft G100 Nickel Duty H4/M5

Key features

- Load Capacity: 3 tons (6,000 lbs) – Suitable for medium to heavy-duty lifting tasks.
- Voltage: 380V – Compatible with electrical systems operating at this voltage level.
- Speed: 1 Speed – Provides a single, fixed lifting speed for general lifting operations.
- 3 Year Warranty, Customer Support and Service in the USA

Electric Chain Hoist Description

This 3-ton electric chain hoist features a power trolley for smooth horizontal movement and single-speed operation for efficient lifting. It operates on a 380V 3-phase 50Hz power supply, delivering reliable performance for a variety of industrial applications.

Our Dedication to Excellence:

At Prowinch, our unwavering commitment to delivering the best price-performance ratio is evident in every Electric Chain Hoist we produce. We subject each unit to meticulous testing and continuously enhance key components, considering factors that influence lifespan. This commitment ensures that we consistently provide a superior product at an optimal price point.

Enhanced Components:

Internally, each component has undergone substantial upgrades to meet the highest quality standards. Key electronic parts are carefully sourced from reputable brands, while locally manufactured lubricants are employed to fortify the durability of gears and reducers. The final assembly and testing processes take place in the US, guaranteeing that every unit surpasses corresponding standards.

Single Speed Efficiency:

Our Single Speed Electric Chain Hoist is designed for straightforward yet efficient lifting operations. Perfect for applications where a consistent lifting speed is paramount, this hoist offers reliability and ease of use.

Duty Classification:

Choosing the right unit is pivotal, and our M5-rated H4 hoists stand out for their excellence in high-volume handling. Tailored for environments like steel warehouses, machine shops, fabricating plants, and mills, these hoists boast a 50% maximum operational time per hour for uniformly distributed work periods. They can efficiently handle up to 300 starts per hour. In scenarios of infrequent work periods, the hoist can operate for 30 minutes from a cold start with up to 300 starts per hour. Operational time ratings adhere to a 65% load factor, following ASME HST-1-2012 guidelines.

Control System:

The Single Speed Electric Chain Hoist comes with a standard pendant control, designed with a length 4 feet less than the lifting height, ensuring easy operation from ground level. For added convenience, an optional wireless control is available.

Advanced Braking System:

Our hoists feature an electromagnetic brake system, rigorously tested at 125% of the hoist capacity. This system is intelligently designed to engage automatically upon any loss of power, ensuring not only enhanced safety but also precise control over the operation of the hoist.

Technical Specifications

Rated Load Capacity	3 ton	Transmission / Reducer Type	Spur gearbox
Standard Lifting Height	30 ft / 9 m	Load Chain Type	G100 Nikel
Speed (f/m) / min	21.26 ft @60Hz 5.40 mt @50Hz	Load Chain Size	11.2 mm
Number of Speeds	1 Speed	Chain Falls	1
Capacity Range	4	Chain Length	30
Voltage	3 Phase 380V 50Hz	Humidity	20%~90%
Total Power Watts	3500	Temperature	-4 ~ 104° F / -20 ~ 40° C
Duty Class	H4/M5/2m/Class D	Trolley Power	500
IEC Motor Protection	IP55	Trolley Speed /min	43.30 ft @60Hz 11 mt @50Hz
Control	Pendant Control IP66 and Optional Wireless	Trolley Number of Speeds	1
Control Voltage	24V	Standards Compliance	ASME HST-1 , ASME B30.16 , B30.17 , EN60204-35
Emergency Stop	Yes	Warranty	3 Year

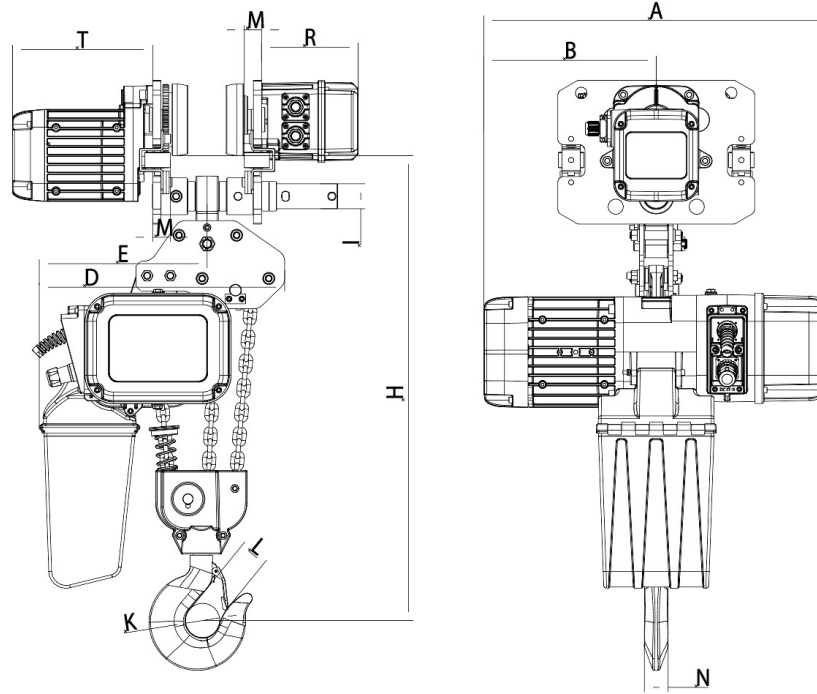

H	A	B	D	E	I	M	N	K	L	T	R
645	590	276	425	290	43	30	34	59	48	242	167

Unit Weight & Dimensions

H Minimum Headroom	645
W Width	420
A Total Height	560
J Hook Opening	59
D Depth	695
Total Weight (w/out cable or Chain)	140
Total Unit Weight	284.9 lbs / 130 Kg

Packaging Weight & Dimensions

Package 1 Net Weight	184.8 lbs / 84 Kg
Package 2 Net Weight	100.1 lbs / 45 Kg
Package 1 Gross Weight	330 lbs / 150 Kg
Package 2 Gross Weight	110 lbs / 50 Kg
Package 1 Length	30 in / 76.2 cm
Package 2 Length	11 in / 27.94 cm
Package 1 Width	20 in / 50.8 cm
Package 2 Width	14 in / 35.56 cm
Package 1 Height	31 in / 78.74 cm
Package 2 Height	23 in / 58.42 cm