



## 3 ton 208~240V / 440~480V Electric Chain Hoist w/ Power Trolley 1 Speed 3ø H4/M5 Duty

### Key features

- Heavy Duty H4/M5 US and EC Standards ASME HST-1 , ASME B30.16 , EN14492-2 , EN60204-32
- Patented Overload Motor Slip Protection with Heavy Duty Electromagnetic Disk Brake
- German Brand Schneider UL Listed Contactors, Dual System Limit Switches, Emergency Stop
- Super Heavy Duty G100 Nickel Chain, 25% Stronger than G80. Standard ASTM A973

3 ton Electric Chain Hoist w/ Power Trolley 1 Speed 208~240V / 440~480V 3ø 60HZ

### Our Dedication to Excellence:

At Prowinch, our unwavering commitment to delivering the best price-performance ratio is evident in every Electric Chain Hoist we produce. We subject each unit to meticulous testing and continuously enhance key components, considering factors that influence lifespan. This commitment ensures that we consistently provide a superior product at an optimal price point.

### Enhanced Components:

Internally, each component has undergone substantial upgrades to meet the highest quality standards. Key electronic parts are carefully sourced from reputable brands, while locally manufactured lubricants are employed to fortify the durability of gears and reducers. The final assembly and testing processes take place in the US, guaranteeing that every unit surpasses corresponding standards.

### Single Speed Efficiency:

Our Single Speed Electric Chain Hoist is designed for straightforward yet efficient lifting operations. Perfect for applications where a consistent lifting speed is paramount, this hoist offers reliability and ease of use.

### Duty Classification:

Choosing the right unit is pivotal, and our M5-rated H4 hoists stand out for their excellence in high-volume handling. Tailored for environments like steel warehouses, machine shops, fabricating plants, and mills, these hoists boast a 50% maximum operational time per hour for uniformly distributed work periods. They can efficiently handle up to 300 starts per hour. In scenarios of infrequent work periods, the hoist can operate for 30 minutes from a cold start with up to 300 starts per hour. Operational time ratings adhere to a 65% load factor, following ASME HST-1-2012 guidelines.

### Control System:

The Single Speed Electric Chain Hoist comes with a standard pendant control, designed with a length 4 feet less than the lifting height, ensuring easy operation from ground level. For added convenience, an optional wireless control is available.

### Advanced Braking System:

Our hoists feature an electromagnetic brake system, rigorously tested at 125% of the hoist capacity. This system is intelligently designed to engage automatically upon any loss of power, ensuring not only enhanced safety but also precise control over the operation of the hoist.

## Technical Specifications

<b>Rated Load Capacity</b>	3 ton	<b>Load Chain weight per foot [lbs]</b>	1.83
<b>Capacity Range</b>	5	<b>Humidity</b>	20%~90%
<b>Voltage</b>	3 Phase 208~240/440~480V 50/60Hz	<b>Temperature</b>	-4 ~ 104° F / -20 ~ 40° C
<b>Standard Lifting Height</b>	30 ft / 9 m	<b>Transmission / Reducer Type</b>	Spur gearbox
<b>Speed (f/m) / min</b>	21.23 ft @60Hz 5.40 mt @50Hz	<b>Reducer Lubrication Type</b>	Oil
<b>Number of Speeds</b>	1 Speed	<b>Paint Specifications</b>	Electrostatic Sprayed Plastic (ESP) Epoxy resins, Polyester Resins, Barium, Pigments
<b>Hoist Contactors Amps</b>	25A	<b>Standards Compliance</b>	ASME HST-1 , ASME B30.16 , B30.17 , EN60204-35
<b>Hoist Contactor Brand</b>	Schneider	<b>Standards Certified</b>	CE
<b>Hoist Contactor Coil Voltage</b>	24 V	<b>Trolley Power</b>	500
<b>Duty Class</b>	H4/M5/2m/Class D	<b>Trolley Number of Speeds</b>	1
<b>IEC Hoist IP Protection</b>	IP55	<b>Trolley Speed /min</b>	43.30 ft @60Hz 11 mt @50Hz
<b>IEC Motor Protection</b>	IP55	<b>Trolley Motor Brake Type and DC Voltage</b>	DC99V/DC207V
<b>Pendant Control Yes No</b>	Yes	<b>Trolley Motor Insulation Grade</b>	F
<b>IEC Pendant Control Protection</b>	IP66	<b>Trolley Contactors Amps</b>	32A
<b>Pendant Control Emergency Stop</b>	Yes	<b>Trolley Contactors Brand</b>	Schneider
<b>Pendant Control total Length</b>	27 ft	<b>Trolley Contactors Brand</b>	Schneider
<b>Hoist Motor Power in KW</b>	3	<b>Trolley Contactors Coil Voltage</b>	24 V
<b>Hoist Motor Brake Type and DC Voltage</b>	DC99V/DC207V	<b>Trolley Wheel Diameter</b>	124
<b>Hoist Motor Insulation Grade</b>	F	<b>Trolley Wheel Material</b>	No. 45 steel
<b>Total Power Watts</b>	4000	<b>Trolley Minimum Turn Radius</b>	1.6
<b>Power Cord Length and Phase Order</b>	3 ft / Black L1 , Red L2 and Blue L3 Green ground	<b>Trolley Beam Range</b>	3.9" to 7"
<b>Recommended Hoist Protection Circuit Breaker AMPs and Type</b>	Type D 25A at 220V and 20A at 460V	<b>Trolley Beam Extension Kit</b>	up to 12"
<b>Optional Load Chain Brand &amp; Country of Origin</b>	FEC Japan	<b>Overload Protection</b>	Overload Motor Clutch
<b>Load Chain Type</b>	G100 Nikel	<b>Hour Meter</b>	Internal Working Hour Meter
<b>Load Chain Size</b>	11.2 mm	<b>Brake SKU</b>	PWRX-2-20-PN.60.61
<b>Chain Falls</b>	1	<b>Brake rectifiers-half-wave</b>	PWRX-BKTF-HW
<b>Chain Length</b>	30	<b>Brake rectifiers-full-wave</b>	PWRX-BKTF-FW

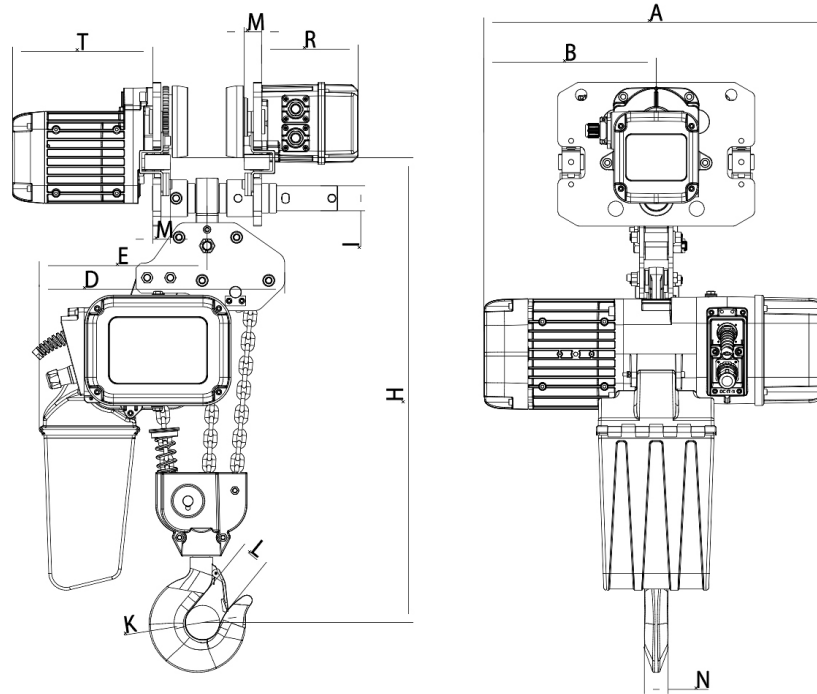

H	A	B	D	E	I	M	N	K	L	T	R
762	590	276	425	290	43	30	34	59	48	242	167

## Unit Weight & Dimensions

<b>A Total Height</b>	560
<b>J Hook Opening</b>	59
<b>W Width</b>	420
<b>H Minimum Headroom</b>	645
<b>D Depth</b>	695
<b>1st Package Type</b>	Wood Crate
<b>Total Weight (w/out cable or Chain)</b>	130
<b>2nd Package Type</b>	Wood Crate
<b>Total Unit Weight</b>	295.9 lbs / 135 Kg

## Packaging Weight & Dimensions

<b>Package 1 Height</b>	31 in / 78.74 cm
<b>Package 2 Height</b>	23 in / 58.42 cm
<b>Package 1 Width</b>	20 in / 50.8 cm
<b>Package 2 Width</b>	14 in / 35.56 cm
<b>Package 1 Length</b>	30 in / 76.2 cm
<b>Package 2 Length</b>	11 in / 27.94 cm
<b>Package 1 Net Weight</b>	184.8 lbs / 84 Kg
<b>Package 2 Net Weight</b>	111.1 lbs / 50 Kg
<b>Package 1 Gross Weight</b>	330 lbs / 150 Kg
<b>Package 2 Gross Weight</b>	121 lbs / 55 Kg