



2 ton Electric Chain Hoist w/ Power Trolley Variable Speed 380V 3ø 50~60HZ 20ft G100 Nickel Duty H4/M5

Key features

- Heavy Duty H4/M5 US and EC Standards ASME HST-1 , ASME B30.16 , EN14492-2 , EN60204-32
- Patented Overload Motor Slip Protection with Heavy Duty Electromagnetic Disk Brake
- Variable Speed Inverter with Potentiometer for Precise Control, Dual System Limit Switches, Emergency Stop
- Super Heavy Duty G100 Nickel Chain, 25% Stronger than G80. Standard ASTM A973

2 ton Electric Chain Hoist w/ Power Trolley Variable Speed 380V 3ø 50~60HZ

Technical Specifications

Rated Load Capacity	2 ton	Chain Length	20 ft (6 m)
Capacity Range	3	Load Chain weight per foot [lbs]	1.48
Voltage	3 Phase 380V 50Hz	Humidity	20%~90%
Standard Lifting Height	20 ft / 6 m	Temperature	-4 ~ 104° F / -20 ~ 40° C
Speed (f/m) / min	ft @60Hz 0.8~6.8 mt @50Hz	Transmission / Reducer Type	Spur gearbox
Number of Speeds	Variable Speed	Reducer Lubrication Type	Oil
Hoist VFD Power	4kW	Paint Specifications	Electrostatic Sprayed Plastic (ESP) Epoxy resins, Polyester Resins, Barium, Pigments
Hoist VFD Brand	HUAYUAN	Standards Compliance	ASME HST-1 , ASME B30.16 , B30.17 , EN60204-34
VFD Model	Z230	Standards Certified	CE
Brake Resistor Kw	1Kw	Trolley Power	500
Duty Class	H4/M5/2m/Class D	Trolley Number of Speeds	Variable
IEC Hoist IP Protection	IP55	Trolley Speed /min	5.9~47.23 ft @60Hz 1.5~12 mt @50Hz
IEC Motor Protection	IP55	Trolley Motor Brake Type and DC Voltage	DC170V
Pendant Control Yes No	Yes	Trolley Motor Insulation Grade	F
IEC Pendant Control Protection	IP66	Trolley VFD Power in KW	2.5kW
Pendant Control Emergency Stop	Yes	Trolley VFD Brand	Huayuan
Pendant Control total Length	17 ft	Trolley VFD Model	Z230
Hoist Motor Power in KW	3	Trolley Wheel Diameter	110
Hoist Motor Brake Type and DC Voltage	DC170V	Trolley Wheel Material	No. 45 steel
Hoist Motor Insulation Grade	F	Trolley Minimum Turn Radius	1.5
Total Power Watts	4000	Trolley Beam Range	3" to 7"
Power Cord Length and Phase Order	3 ft / Red L1, White L2 and Black L3, Green ground	Trolley Beam Extension Kit	up to 12"
Recommended Hoist Protection Circuit Breaker AMPs and Type	Type D 20A	Overload Protection	Overload Motor Clutch
Optional Load Chain Brand & Country of Origin	FEC Japan	Hour Meter	Internal Working Hour Meter
Load Chain Type	G100 Nikel	Brake SKU	PWRX-2-20-PN.60.61
Load Chain Size	10 mm	Brake rectifiers-half-wave	PWRX-BKTF-HW
Chain Falls	1		

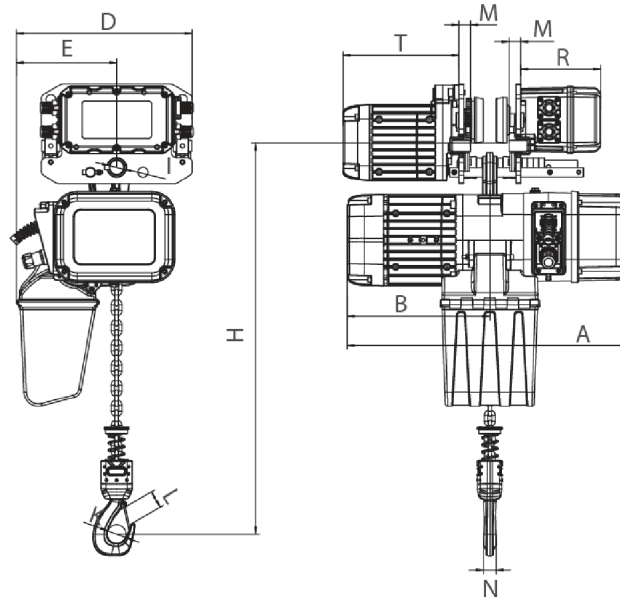

Rated load (t)	Type	Dimension (mm)												
		Minimum distance from the bottom of the track to the bottom hook: H	A	L	B	D	E	I	M	N	K	L	T	R
1	PWRXT1-01	473	440	3500-5500	285	210	20	105	140					
2	PWRXT2-01	516	590		276	368	210	31	24	25	42	32	242	167
3	PWRXT3-01	600	681		350	422	264	36	28	35	52	42	242	167
5	PWRXT5-02	645	681		350	478	307	43	30	34	59	48	242	167

Unit Weight & Dimensions

A Total Height	600
J Hook Opening	52

Packaging Weight & Dimensions

Package 1 Height	31 in / 78.74 cm
Package 2 Height	23 in / 58.42 cm

W Width	422	Package 1 Width	20 in / 50.8 cm
H Minimum Headroom	600	Package 2 Width	14 in / 35.56 cm
D Depth	600	Package 1 Length	30 in / 76.2 cm
1st Package Type	Wood Crate	Package 2 Length	11 in / 27.94 cm
Total Weight (w/out cable or Chain)	155	Package 1 Net Weight	184.8 lbs / 84 Kg
2nd Package Type	Wood Crate	Package 2 Net Weight	100.1 lbs / 45 Kg
Total Unit Weight	284.9 lbs / 130 Kg	Package 1 Gross Weight	308 lbs / 140 Kg
		Package 2 Gross Weight	110 lbs / 50 Kg