



2 ton Electric Chain Hoist w/ Power Trolley Variable Speed 110V 1Ø 60HZ

2 ton Electric Chain Hoist w/ Power Trolley Variable Speed 110V 1Ø 60HZ

Technical Specifications

Rated Load Capacity	2 ton	Load Chain Size	10 mm
Capacity Range	4	Chain Falls	1
Voltage	1 Phase 110~120V 60Hz	Chain Length	20
Standard Lifting Height	20 ft / 6 m	Load Chain weight per foot [lbs]	1.48
Speed (f/m) / min	ft @60Hz 0.8~6.8 mt @50Hz	Humidity	20%~90%
Number of Speeds	Variable Speed	Temperature	-4 ~ 104° F / -20 ~ 40° C
Hoist VFD Power	4kW	Transmission / Reducer Type	Spur gearbox
Hoist VFD Brand	HUAYUAN	Reducer Lubrication Type	Oil
VFD Model	Z230	Paint Specifications	Electrostatic Sprayed Plastic (ESP) Epoxy resins, Polyester Resins, Barium, Pigments
Brake Resistor Kw	1Kw	Standards Compliance	ASME HST-1 , ASME B30.16 , B30.17 , EN60204-34
Duty Class	H4/M5/2m/Class D	Standards Certified	CE
IEC Hoist IP Protection	IP55	Trolley Power	500
IEC Motor Protection	IP55	Trolley Number of Speeds	Variable
Pendant Control Yes No	Yes	Trolley Speed /min	5.9~47.23 ft @60Hz 1.5~12 mt @50Hz
IEC Pendant Control Protection	IP66	Trolley Motor Brake Type and DC Voltage	DC170V
Pendant Control Emergency Stop	Yes	Trolley Motor Insulation Grade	F
Pendant Control total Length	17 ft	Trolley VFD Power in KW	2.5kW
Hoist Motor Power in KW	3	Trolley VFD Brand	Huayuan
Hoist Motor Brake Type and DC Voltage	DC170V	Trolley VFD Model	Z230
Hoist Motor Insulation Grade	F	Trolley Wheel Diameter	110
Total Power Watts	4000	Trolley Wheel Material	No. 45 steel
Power Cord Length and Phase Order	3 ft / Black L1, White, Green ground	Trolley Minimum Turn Radius	1.5
Recommended Hoist Protection Circuit Breaker AMPs and Type	Type D 20A	Trolley Beam Range	3" to 7"
Optional Load Chain Brand & Country of Origin	FEC Japan	Trolley Beam Extension Kit	up to 12"
Load Chain Type	G100 Nikel		

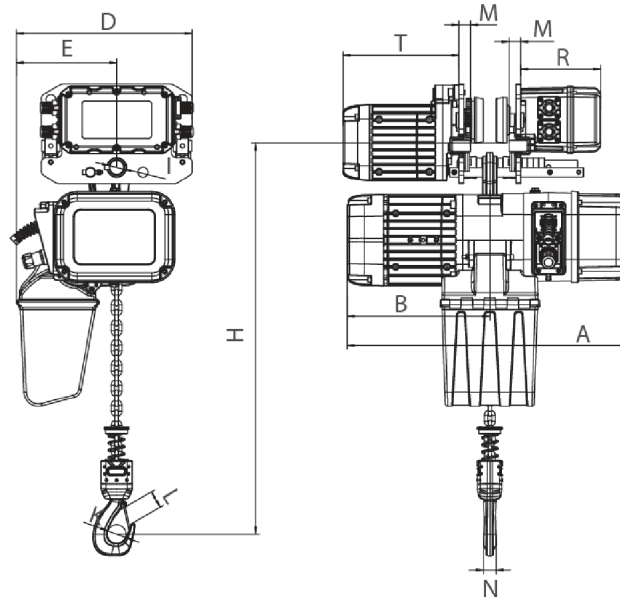

Rated load (t)	Type	Dimension (mm)												
		Minimum distance from the bottom of the track to the bottom hook: H	A	L	B	D	E	I	M	N	K	L	T	R
1	PWRXT1-01	473	440	3500-5500	285	210	20	105	140					
2	PWRXT2-01	516	590		276	368	210	31	24	25	42	32	242	167
3	PWRXT3-01	600	681		350	422	264	36	28	35	52	42	242	167
5	PWRXT5-02	645	681		350	478	307	43	30	34	59	48	242	167

Unit Weight & Dimensions

A Total Height	600
J Hook Opening	52

Packaging Weight & Dimensions

Package 1 Height	31 in / 78.74 cm
Package 2 Height	23 in / 58.42 cm

W Width	422	Package 1 Width	20 in / 50.8 cm
H Minimum Headroom	600	Package 2 Width	14 in / 35.56 cm
D Depth	600	Package 1 Length	30 in / 76.2 cm
1st Package Type	Wood Crate	Package 2 Length	11 in / 27.94 cm
Total Weight (w/out cable or Chain)	155	Package 1 Net Weight	184.8 lbs / 84 Kg
2nd Package Type	Wood Crate	Package 2 Net Weight	100.1 lbs / 45 Kg
Total Unit Weight	284.9 lbs / 130 Kg	Package 1 Gross Weight	308 lbs / 140 Kg
		Package 2 Gross Weight	110 lbs / 50 Kg