



## 2 ton Electric Chain Hoist w/ Power Trolley 2 Speed 208~240V / 440~480V 3ø 60HZ 20ft G100 Nickel Duty H4/M5

### Key features

- Load Capacity: 2 tons (4,000 lbs) – Suitable for lifting heavy loads efficiently.
- Voltage: 208~240V / 440~480V- Compatible with various electrical systems, making it adaptable to different environments.
- Speed: 2 Speed – Allows for both high-speed and low-speed lifting options, providing versatility for different lifting tasks.
- 3 Year Warranty, Customer Support and Service in the USA

### Electric Chain Hoist Description

This 2-ton electric chain hoist comes with a power trolley and offers dual-speed operation for versatile lifting and smooth horizontal movement. It supports dual voltage options (208~240V / 440~480V) with a 3-phase 60Hz power supply, providing efficient and reliable performance for various industrial applications.

### Our Dedication to Excellence:

At Prowinch, our unwavering commitment to delivering the best price-performance ratio is evident in every Electric Chain Hoist we produce. We subject each unit to meticulous testing and continuously enhance key components, considering factors that influence lifespan. This commitment ensures that we consistently provide a superior product at an optimal price point.

### Enhanced Components:

Internally, each component has undergone substantial upgrades to meet the highest quality standards. Key electronic parts are carefully sourced from reputable brands, while locally manufactured lubricants are employed to fortify the durability of gears and reducers. The final assembly and testing processes take place in the US, guaranteeing that every unit surpasses corresponding standards.

### Double Speed Precision:

Our Double Speed Electric Chain Hoist is engineered for versatility in lifting operations. Offering both high and low-speed options, this hoist provides precision and adaptability, making it suitable for a wide range of applications.

### Duty Classification:

Choosing the right unit is pivotal, and our M5-rated H4 hoists stand out for their excellence in high-volume handling. Tailored for environments like steel warehouses, machine shops, fabricating plants, and mills, these hoists boast a 50% maximum operational time per hour for uniformly distributed work periods. They can efficiently handle up to 300 starts per hour. In scenarios of infrequent work periods, the hoist can operate for 30 minutes from a cold start with up to 300 starts per hour. Operational time ratings adhere to a 65% load factor, following ASME HST-1-2012 guidelines.

### Control System:

The Double Speed Electric Chain Hoist features an advanced control system, providing flexibility with both high and low-speed options. The standard pendant control, designed with a length 4 feet less than the lifting height, ensures easy operation from ground level. For added convenience, an optional wireless control is available.

## Advanced Braking System:

Our hoists feature an electromagnetic brake system, rigorously tested at 125% of the hoist capacity. This system is intelligently designed to engage automatically upon any loss of power, ensuring not only enhanced safety but also precise control over the operation of the hoist.

## Technical Specifications

<b>Rated Load Capacity</b>	2 ton	<b>Load Chain Size</b>	10 mm
<b>Standard Lifting Height</b>	20 ft / 6 m	<b>Chain Falls</b>	1
<b>Speed (f/m) / min</b>	8.7/ 26.8 ft @60Hz 2.2/6.8 mt @50Hz	<b>Chain Length</b>	20
<b>Capacity Range</b>	3	<b>Humidity</b>	20%~90%
<b>Voltage</b>	3 Phase 208~240/440~480V 50/60Hz	<b>Temperature</b>	-4 ~ 104° F / -20 ~ 40° C
<b>Total Power Watts</b>	3500	<b>Trolley Power</b>	500
<b>Duty Class</b>	H4/M5/2m/Class D	<b>Trolley Speed /min</b>	14.17~43.30 ft @60Hz 3.6~11 mt @50Hz
<b>IEC Motor Protection</b>	IP55	<b>Trolley Number of Speeds</b>	2
<b>Control</b>	Pendant Control IP66 and Optional Wireless	<b>I-Beam Width Range</b>	3" to 7"
<b>Control Voltage</b>	24V	<b>Minimum Turn Radius</b>	1.5
<b>Emergency Stop</b>	Yes	<b>Standards Compliance</b>	ASME HST-1 , ASME B30.16 , B30.17 , EN60204-34
<b>Transmission / Reducer Type</b>	Spur gearbox	<b>Warranty</b>	3 Year
<b>Load Chain Type</b>	G100 Nickel		

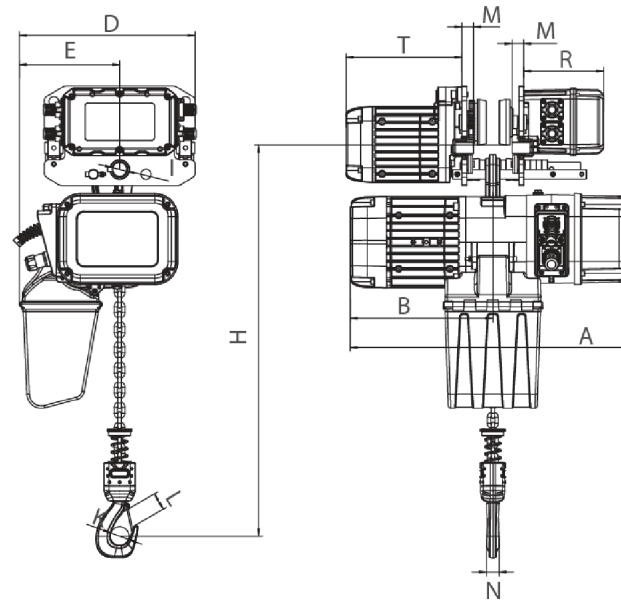

Rated load (t)	Type	Dimension (mm)												
		Minimum distance from the bottom of the track to the bottom hook: H	A	L	B	D	E	I	M	N	K	L	T	R
1	PWRXT1-01	473	440	3500-5500	285	210	20	105	140					
2	PWRXT2-01	516	590		276	368	210	31	24	25	42	32	242	167
3	PWRXT3-01	600	681		350	422	264	36	28	35	52	42	242	167
5	PWRXT5-02	645	681		350	478	307	43	30	34	59	48	242	167

### Unit Weight & Dimensions

H Minimum Headroom	600
W Width	422

### Packaging Weight & Dimensions

Package 1 Net Weight	184.8 lbs / 84 Kg
Package 2 Net Weight	172.7 lbs / 78 Kg

<b>A Total Height</b>	600	<b>Package 1 Gross Weight</b>	308 lbs / 140 Kg
<b>J Hook Opening</b>	52	<b>Package 2 Gross Weight</b>	187 lbs / 85 Kg
<b>D Depth</b>	600	<b>Package 1 Length</b>	30 in / 76.2 cm
<b>Total Weight (w/out cable or Chain)</b>	155	<b>Package 2 Length</b>	11 in / 27.94 cm
<b>Total Unit Weight</b>	357.5 lbs / 163 Kg	<b>Package 1 Width</b>	20 in / 50.8 cm
		<b>Package 2 Width</b>	14 in / 35.56 cm
		<b>Package 1 Height</b>	31 in / 78.74 cm
		<b>Package 2 Height</b>	23 in / 58.42 cm