



1 ton Electric Chain Hoist w/ Power Trolley Variable Speed 220V 1ø 50~60HZ 20ft G100 Nickel Duty H4/M5

Key features

- Capacity: Lifts up to 1 ton (approximately 2,000 lbs)
- Power Supply: 220V single-phase, compatible with 50~60Hz
- Speed Control: Variable speed operation for accurate lifting and lowering
- 3 Year Warranty, Customer Support and Service in the USA

Electric Chain Hoist Description

The 1 Ton Electric Chain Hoist with Power Trolley is a powerful and versatile lifting solution designed for a variety of applications. With variable speed control, this hoist allows for precise handling of loads up to 2,000 lbs. It operates on a 220V single-phase power supply, compatible with both 50 and 60Hz, making it suitable for different settings. The integrated power trolley ensures smooth horizontal movement, ideal for tasks that require flexibility and accuracy.

Technical Specifications

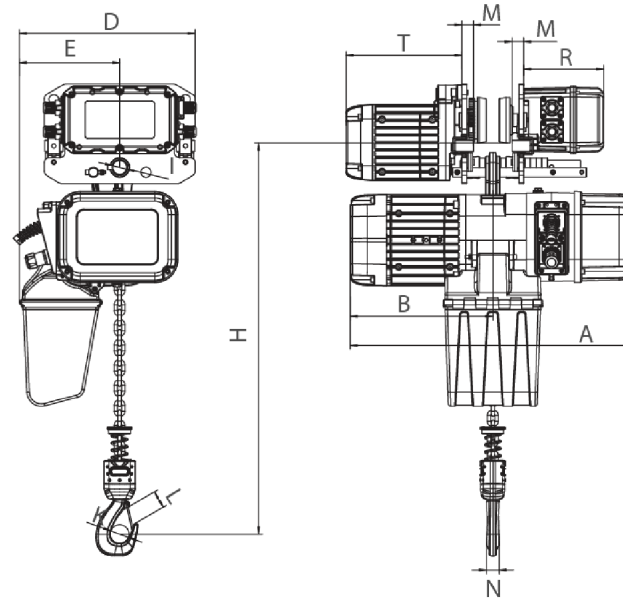

Rated load (t)	Type	Dimension (mm)												
		Minimum distance from the bottom of the track to the bottom hook: H	A	L	B	D	E	I	M	N	K	L	T	R
1	PWRXT1-01	473	440	3500-5500	285	210	20	105	140					
2	PWRXT2-01	516	590		276	368	210	31	24	25	42	32	242	167
3	PWRXT3-01	600	681		350	422	264	36	28	35	52	42	242	167
5	PWRXT5-02	645	681		350	478	307	43	30	34	59	48	242	167

Unit Weight & Dimensions

Total Unit Weight

190.74 lbs / 87 Kg