



1 ton Electric Chain Hoist w/ Power Trolley Variable Speed 440~480V 3ø 50~60HZ 20ft G100 Nickel Duty H4/M5

Key features

- Load Capacity: 1 ton (2000 lbs) – Suitable for handling moderate to heavy loads.
- 440~480V: Designed for high voltage systems, suitable for industrial environments.
- Variable Speed: Provides adjustable speed control for precise handling of loads.
- 3 Year Warranty, Customer Support and Service in the USA

Electric Chain Hoist Description

This 1-ton electric chain hoist features a power trolley for smooth horizontal movement and variable speed control for precise lifting. It operates on a 440~480V 3-phase 50/60Hz power supply, offering versatile and reliable performance suitable for a range of industrial applications.

Our Dedication to Excellence:

At Prowinch, our unwavering commitment to delivering the best price-performance ratio is evident in every Electric Chain Hoist we produce. We subject each unit to meticulous testing and continuously enhance key components, considering factors that influence lifespan. This commitment ensures that we consistently provide a superior product at an optimal price point.

Enhanced Components:

Internally, each component has undergone substantial upgrades to meet the highest quality standards. Key electronic parts are carefully sourced from reputable brands, while locally manufactured lubricants are employed to fortify the durability of gears and reducers. The final assembly and testing processes take place in the US, guaranteeing that every unit surpasses corresponding standards.

Variable Speed Innovation:

Designed for unparalleled control, our Variable Speed Electric Chain Hoist offers a dynamic lifting experience. Ideal for applications requiring precise load positioning, this hoist allows you to adjust lifting speeds according to the specific needs of your project.

Duty Classification:

Choosing the right unit is pivotal, and our M5-rated H4 hoists stand out for their excellence in high-volume handling. Tailored for environments like steel warehouses, machine shops, fabricating plants, and mills, these hoists boast a 50% maximum operational time per hour for uniformly distributed work periods. They can efficiently handle up to 300 starts per hour. In scenarios of infrequent work periods, the hoist can operate for 30 minutes from a cold start with up to 300 starts per hour. Operational time ratings adhere to a 65% load factor, following ASME HST-1-2012 guidelines.

Control System:

The Variable Speed Electric Chain Hoist is equipped with an advanced control system, allowing for precise speed adjustments tailored to your lifting requirements. The standard pendant control, designed with a length 4 feet less than the lifting height, ensures easy operation from ground level. For added convenience, an optional wireless control is available.

Advanced Braking System:

Our hoists feature an electromagnetic brake system, rigorously tested at 125% of the hoist capacity. This system is intelligently designed to engage automatically upon any loss of power, ensuring not only enhanced safety but also precise control over the operation of the hoist.

Technical Specifications

Rated Load Capacity	1 ton	Load Chain Type	G100 Nickel
Standard Lifting Height	20 ft / 6 m	Load Chain Size	7.1 mm
Speed (f/m) / min	3.1~27.5 ft @60Hz mt @50Hz	Chain Falls	1
Number of Speeds	Variable Speed	Chain Length	20
Voltage	3 Phase 440~480V 60Hz	Humidity	20%~90%
Total Power Watts	4000	Temperature	-4 ~ 104° F / -20 ~ 40° C
Duty Class	H4/M5/2m/Class D	Trolley Power	500
IEC Motor Protection	IP55	Trolley Speed /min	5.9~47.23 ft @60Hz 1.5~12 mt @50Hz
Control	Pendant Control IP66 and Optional Wireless	Trolley Number of Speeds	Variable
Control Voltage	24V	Standards Compliance	ASME HST-1 , ASME B30.16 , B30.17 , EN60204-33
Emergency Stop	Yes	Warranty	3 Year
Transmission / Reducer Type	Spur gearbox		

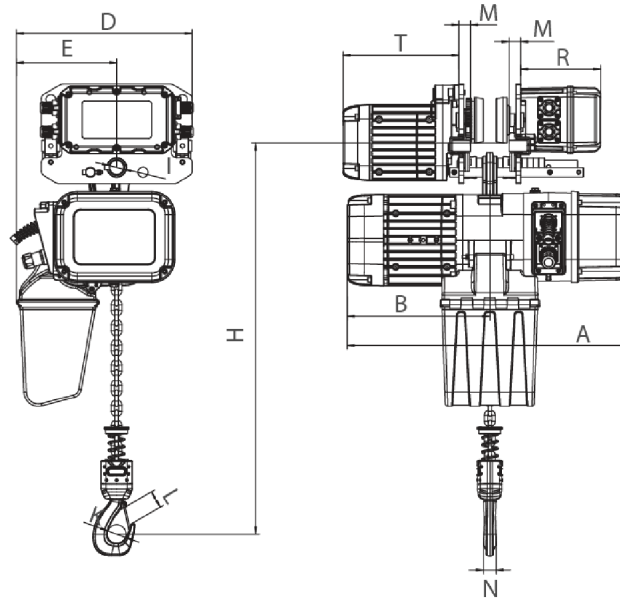

Rated load (t)	Type	Dimension (mm)												
		Minimum distance from the bottom of the track to the bottom hook: H	A	L	B	D	E	I	M	N	K	L	T	R
1	PWRXT1-01	473	440	3500-5500	285	210	20	105	140					
2	PWRXT2-01	516	590		276	368	210	31	24	25	42	32	242	167
3	PWRXT3-01	600	681		350	422	264	36	28	35	52	42	242	167
5	PWRXT5-02	645	681		350	478	307	43	30	34	59	48	242	167

Unit Weight & Dimensions

H Minimum Headroom	516
W Width	368

Packaging Weight & Dimensions

Package 1 Net Weight	101.64 lbs / 46 Kg
Package 2 Net Weight	89.1 lbs / 40 Kg

A Total Height	516	Package 1 Gross Weight	209 lbs / 95 Kg
J Hook Opening	42	Package 2 Gross Weight	99 lbs / 45 Kg
D Depth	590	Package 1 Length	26 in / 66.04 cm
Total Weight (w/out cable or Chain)	86	Package 2 Length	11 in / 27.94 cm
Total Unit Weight	190.74 lbs / 87 Kg	Package 1 Width	16 in / 40.64 cm
		Package 2 Width	14 in / 35.56 cm
		Package 1 Height	26 in / 66.04 cm
		Package 2 Height	23 in / 58.42 cm