



1 ton Electric Chain Hoist w/ Power Trolley 1 Speed 380V 3ø 50HZ 20ft G100 Nickel Duty H4/M5

Key features

- Heavy Duty H4/M5 US and EC Standards ASME HST-1 , ASME B30.16 , EN14492-2 , EN60204-32
- Patented Overload Motor Slip Protection with Heavy Duty Electromagnetic Disk Brake
- German Brand Schneider UL Listed Contactors, Dual System Limit Switches, Emergency Stop
- Super Heavy Duty G100 Nickel Chain, 25% Stronger than G80. Standard ASTM A973

1 ton Electric Chain Hoist w/ Power Trolley 1 Speed 380V 3ø 50HZ

Our Dedication to Excellence:

At Prowinch, our unwavering commitment to delivering the best price-performance ratio is evident in every Electric Chain Hoist we produce. We subject each unit to meticulous testing and continuously enhance key components, considering factors that influence lifespan. This commitment ensures that we consistently provide a superior product at an optimal price point.

Enhanced Components:

Internally, each component has undergone substantial upgrades to meet the highest quality standards. Key electronic parts are carefully sourced from reputable brands, while locally manufactured lubricants are employed to fortify the durability of gears and reducers. The final assembly and testing processes take place in the US, guaranteeing that every unit surpasses corresponding standards.

Single Speed Efficiency:

Our Single Speed Electric Chain Hoist is designed for straightforward yet efficient lifting operations. Perfect for applications where a consistent lifting speed is paramount, this hoist offers reliability and ease of use.

Duty Classification:

Choosing the right unit is pivotal, and our M5-rated H4 hoists stand out for their excellence in high-volume handling. Tailored for environments like steel warehouses, machine shops, fabricating plants, and mills, these hoists boast a 50% maximum operational time per hour for uniformly distributed work periods. They can efficiently handle up to 300 starts per hour. In scenarios of infrequent work periods, the hoist can operate for 30 minutes from a cold start with up to 300 starts per hour. Operational time ratings adhere to a 65% load factor, following ASME HST-1-2012 guidelines.

Control System:

The Single Speed Electric Chain Hoist comes with a standard pendant control, designed with a length 4 feet less than the lifting height, ensuring easy operation from ground level. For added convenience, an optional wireless control is available.

Advanced Braking System:

Our hoists feature an electromagnetic brake system, rigorously tested at 125% of the hoist capacity. This system is intelligently designed to engage automatically upon any loss of power, ensuring not only enhanced safety but also precise control over the operation of the hoist.

Technical Specifications

Rated Load Capacity	1 ton	Chain Length	20
Capacity Range	2	Load Chain weight per foot [lbs]	0.58
Voltage	3 Phase 380V 50Hz	Humidity	20%~90%
Standard Lifting Height	20 ft / 6 m	Temperature	-4 ~ 104° F / -20 ~ 40° C
Speed (f/m) / min	25.60 ft @60Hz 6.50 mt @50Hz	Transmission / Reducer Type	Spur gearbox
Number of Speeds	1 Speed	Reducer Lubrication Type	Oil
Hoist Contactors Amps	18A	Paint Specifications	Electrostatic Sprayed Plastic (ESP) Epoxy resins, Polyester Resins, Barium, Pigments
Hoist Contactor Brand	Schneider	Standards Compliance	ASME HST-1 , ASME B30.16 , B30.17 , EN60204-33
Hoist Contactor Coil Voltage	24 V	Standards Certified	CE
Duty Class	H4/M5/2m/Class D	Trolley Power	500
IEC Hoist IP Protection	IP55	Trolley Number of Speeds	1
IEC Motor Protection	IP55	Trolley Speed /min	43.30 ft @60Hz 11 mt @50Hz
Pendant Control Yes No	Yes	Trolley Motor Brake Type and DC Voltage	DC170V
IEC Pendant Control Protection	IP66	Trolley Motor Insulation Grade	F
Pendant Control Emergency Stop	Yes	Trolley Contactors Amps	32A
Pendant Control total Length	17 ft	Trolley Contactors Brand	Schneider
Hoist Motor Power in KW	1.5	Trolley Contactors Coil Voltage	24 V
Hoist Motor Brake Type and DC Voltage	DC170V	Trolley Wheel Diameter	95
Hoist Motor Insulation Grade	F	Trolley Wheel Material	No. 45 steel
Total Power Watts	2000	Trolley Minimum Turn Radius	1.3
Power Cord Length and Phase Order	3 ft / Red L1, White L2 and Black L3, Green ground	Trolley Beam Range	2" to 6"
Recommended Hoist Protection Circuit Breaker AMPs and Type	Type D 15A	Trolley Beam Extension Kit	up to 12"
Optional Load Chain Brand & Country of Origin	FEC Japan	Overload Protection	Overload Motor Clutch
Load Chain Type	G100 Nikel	Hour Meter	Internal Working Hour Meter
Load Chain Size	7.1 mm	Brake SKU	PWRX-1-PN.60.61
Chain Falls	1	Brake rectifiers-half-wave	PWRX-BKTF-HW

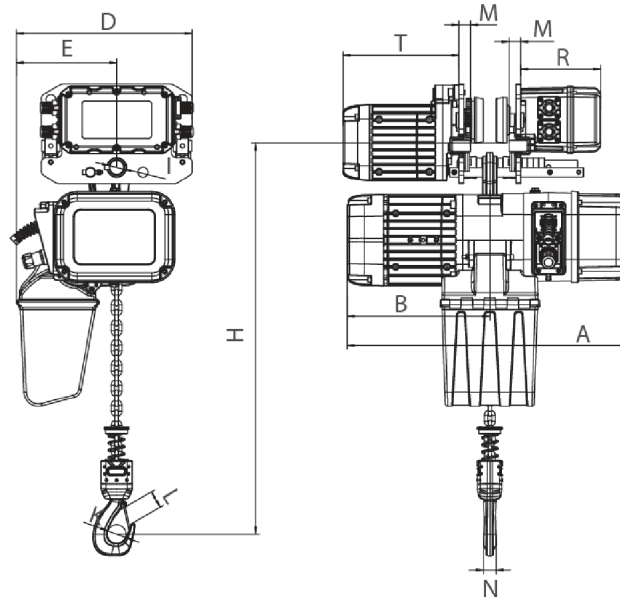

Rated load (t)	Type	Dimension (mm)													
		Minimum distance from the bottom of the track to the bottom hook: H	A	L	B	D	E	I	M	N	K	L	T	R	
1	PWRXT1-01	473	440	3500-5500	285	210	20	105	140						
2	PWRXT2-01	516	590		276	368	210	31	24	25	42	32	242	167	
3	PWRXT3-01	600	681		350	422	264	36	28	35	52	42	242	167	
5	PWRXT5-02	645	681		350	478	307	43	30	34	59	48	242	167	

Unit Weight & Dimensions

A Total Height	455
J Hook Opening	42

Packaging Weight & Dimensions

Package 1 Height	26 in / 66.04 cm
Package 2 Height	20 in / 50.8 cm

W Width	330	Package 1 Width	16 in / 40.64 cm
H Minimum Headroom	516	Package 2 Width	13 in / 33.02 cm
D Depth	590	Package 1 Length	26 in / 66.04 cm
1st Package Type	Wood Crate	Package 2 Length	8 in / 20.32 cm
Total Weight (w/out cable or Chain)	90	Package 1 Net Weight	101.64 lbs / 46 Kg
2nd Package Type	Wood Crate	Package 2 Net Weight	62.48 lbs / 28 Kg
Total Unit Weight	164.12 lbs / 75 Kg	Package 1 Gross Weight	209 lbs / 95 Kg
		Package 2 Gross Weight	70.4 lbs / 32 Kg