



1/2 ton Electric Chain Hoist w/ Power Trolley Variable Speed 380V 3ø 50~60HZ 13ft G100 Nickel Duty H4/M5

Key features

- Heavy Duty H4/M5 US and EC Standards ASME HST-1 , ASME B30.16 , EN14492-2 , EN60204-32
- Patented Overload Motor Slip Protection with Heavy Duty Electromagnetic Disk Brake
- Variable Speed Inverter with Potentiometer for Precise Control, Dual System Limit Switches, Emergency Stop
- Super Heavy Duty G100 Nickel Chain, 25% Stronger than G80. Standard ASTM A973

1/2 ton Electric Chain Hoist w/ Power Trolley Variable Speed 380V 3ø 50~60HZ

Technical Specifications

Rated Load Capacity	1/2 ton	Chain Length	13 ft (4 m)
Capacity Range	1	Load Chain weight per foot [lbs]	0.58
Voltage	3 Phase 380V 50Hz	Humidity	20%~90%
Standard Lifting Height	13 ft / 4 m	Temperature	-4 ~ 104° F / -20 ~ 40° C
Speed (f/m) / min	ft @60Hz 1~8 mt @50Hz	Transmission / Reducer Type	Spur gearbox
Number of Speeds	Variable Speed	Reducer Lubrication Type	Oil
Hoist VFD Power	1.5kW	Paint Specifications	Electrostatic Sprayed Plastic (ESP) Epoxy resins, Polyester Resins, Barium, Pigments
Hoist VFD Brand	HUAYUAN	Standards Compliance	ASME HST-1 , ASME B30.16 , EN60204-37
VFD Model	Z230	Standards Certified	CE
Brake Resistor Kw	0.3Kw	Trolley Power	500
Duty Class	H4/M5/2m/Class D	Trolley Number of Speeds	Variable
IEC Hoist IP Protection	IP55	Trolley Speed /min	5.9~47.23 ft @60Hz 1.5~12 mt @50Hz
IEC Motor Protection	IP55	Trolley Motor Brake Type and DC Voltage	DC170V
Pendant Control Yes No	Yes	Trolley Motor Insulation Grade	F
IEC Pendant Control Protection	IP66	Trolley VFD Power in KW	2.5kW
Pendant Control Emergency Stop	Yes	Trolley VFD Brand	Huayuan
Pendant Control total Length	10 ft	Trolley VFD Model	Z230
Hoist Motor Power in KW	0.75	Trolley Wheel Diameter	95
Hoist Motor Brake Type and DC Voltage	DC170V	Trolley Wheel Material	No. 45 steel
Hoist Motor Insulation Grade	F	Trolley Minimum Turn Radius	1.3
Total Power Watts	1500	Trolley Beam Range	3" to 5"
Power Cord Length and Phase Order	3 ft / Red L1, White L2 and Black L3, Green ground	Trolley Beam Extension Kit	up to 12"
Recommended Hoist Protection Circuit Breaker AMPs and Type	Type D 10A	Overload Protection	Overload Motor Clutch
Optional Load Chain Brand & Country of Origin	FEC Japan	Hour Meter	Internal Working Hour Meter
Load Chain Type	G100 Nikel	Brake SKU	PWRX-0.25-0.5-PN.4.11
Load Chain Size	6.3mm	Brake rectifiers-half-wave	PWRX-BKTF-HW
Chain Falls	1		

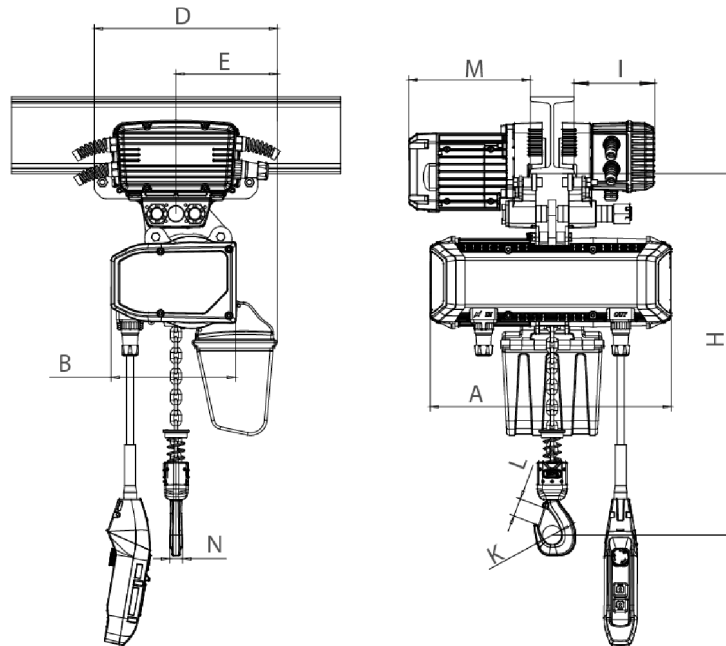

Rated load (t)	Type	Dimension (mm)									
		Minimum distance from the bottom of the track to the bottom hook: H	A	L	B	D	E	I	M	N	K
0.25-0.5	PWRXT0.25-0.5-VS	473	447	3500-5500	217	334	152	147	220	20	35

Unit Weight & Dimensions

A Total Height	396
J Hook Opening	35
W Width	305
H Minimum Headroom	396

Packaging Weight & Dimensions

Package 1 Height	20 in / 50.8 cm
Package 2 Height	20 in / 50.8 cm
Package 1 Width	15 in / 38.1 cm
Package 2 Width	13 in / 33.02 cm

D Depth	440	Package 1 Length	20 in / 50.8 cm
1st Package Type	Wood Crate	Package 2 Length	8 in / 20.32 cm
Total Weight (w/out cable or Chain)	64	Package 1 Net Weight	72.16 lbs / 33 Kg
2nd Package Type	Wood Crate	Package 2 Net Weight	62.48 lbs / 28 Kg
Total Unit Weight	134.64 lbs / 62 Kg	Package 1 Gross Weight	85.8 lbs / 39 Kg
		Package 2 Gross Weight	70.4 lbs / 32 Kg