



1/2 ton Electric Chain Hoist w/ Power Trolley Variable Speed 110V 1ø 60HZ

1/2 ton Electric Chain Hoist w/ Power Trolley Variable Speed 110V 1ø 60HZ

Technical Specifications

Rated Load Capacity	1/2 ton	Load Chain Size	6.3mm
Capacity Range	2	Chain Falls	1
Voltage	1 Phase 110~120V 60Hz	Chain Length	13
Standard Lifting Height	13 ft / 4 m	Load Chain weight per foot [lbs]	0.58
Speed (f/m) / min	ft @60Hz 1~8 mt @50Hz	Humidity	20%~90%
Number of Speeds	Variable Speed	Temperature	-4 ~ 104° F / -20 ~ 40° C
Hoist VFD Power	1.5kW	Transmission / Reducer Type	Spur gearbox
Hoist VFD Brand	HUAYUAN	Reducer Lubrication Type	Oil
VFD Model	Z230	Paint Specifications	Electrostatic Sprayed Plastic (ESP) Epoxy resins, Polyester Resins, Barium, Pigments
Brake Resistor Kw	0.3Kw	Standards Compliance	ASME HST-1 , ASME B30.16 , EN60204-37
Duty Class	H4/M5/2m/Class D	Standards Certified	CE
IEC Hoist IP Protection	IP55	Trolley Power	500
IEC Motor Protection	IP55	Trolley Number of Speeds	Variable
Pendant Control Yes No	Yes	Trolley Speed /min	5.9~47.23 ft @60Hz 1.5~12 mt @50Hz
IEC Pendant Control Protection	IP66	Trolley Motor Brake Type and DC Voltage	DC170V
Pendant Control Emergency Stop	Yes	Trolley Motor Insulation Grade	F
Pendant Control total Length	10 ft	Trolley VFD Power in KW	2.5kW
Hoist Motor Power in KW	0.75	Trolley VFD Brand	Huayuan
Hoist Motor Brake Type and DC Voltage	DC170V	Trolley VFD Model	Z230
Hoist Motor Insulation Grade	F	Trolley Wheel Diameter	95
Total Power Watts	1500	Trolley Wheel Material	No. 45 steel
Power Cord Length and Phase Order	3 ft / Black L1, White, Green ground	Trolley Minimum Turn Radius	1.3
Recommended Hoist Protection Circuit Breaker AMPs and Type	Type D 10A	Trolley Beam Range	3" to 5"
Optional Load Chain Brand & Country of Origin	FEC Japan	Trolley Beam Extension Kit	up to 12"
Load Chain Type	G100 Nikel		

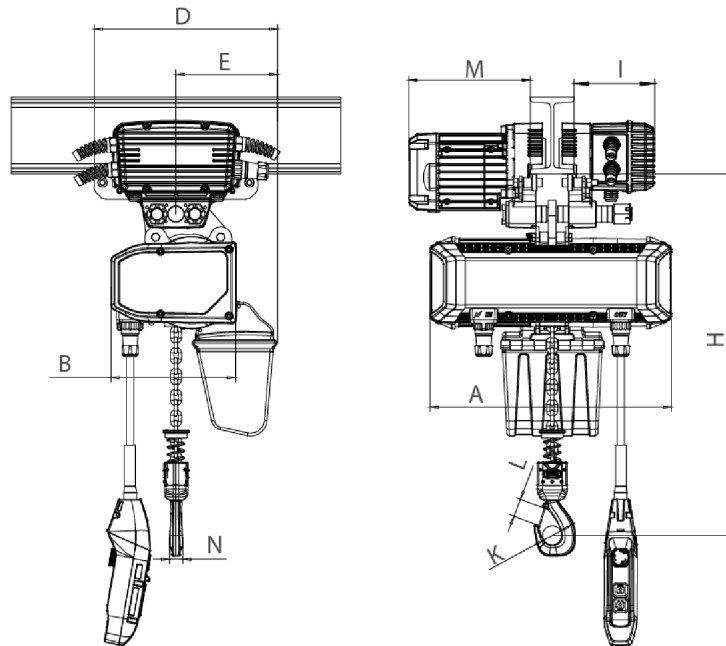

Rated load (t)	Type	Dimension (mm)							
		Minimum distance from the bottom of the track to the bottom hook: H	A	L	B	D	E	I	M
0.25	PWRXT0.25-01	473	440	3500-5500	285	210	20	105	140
0.5	PWRXT0.5-01	473	440		285	210	20	105	140

Unit Weight & Dimensions

A Total Height	396
J Hook Opening	35
W Width	305
H Minimum Headroom	396

Packaging Weight & Dimensions

Package 1 Height	20 in / 50.8 cm
Package 2 Height	20 in / 50.8 cm
Package 1 Width	15 in / 38.1 cm
Package 2 Width	13 in / 33.02 cm

D Depth	440	Package 1 Length	20 in / 50.8 cm
1st Package Type	Wood Crate	Package 2 Length	8 in / 20.32 cm
Total Weight (w/out cable or Chain)	64	Package 1 Net Weight	72.16 lbs / 33 Kg
2nd Package Type	Wood Crate	Package 2 Net Weight	62.48 lbs / 28 Kg
Total Unit Weight	134.64 lbs / 62 Kg	Package 1 Gross Weight	85.8 lbs / 39 Kg
		Package 2 Gross Weight	70.4 lbs / 32 Kg