



1/4 ton Electric Chain Hoist w/ Power Trolley Variable Speed 380V 3ø 50~60HZ 13ft G100 Nickel Duty H4/M5

Key features

- Load Capacity: 1/4 ton (500 lbs.), suitable for light-duty lifting tasks.
- Voltage: Operates at 380V, 3-phase electrical systems, compatible with both 50~60HZ frequencies, making it adaptable for various international standards.
- Variable Speed Operation: Allows for precise control over lifting speed, enhancing flexibility for different lifting needs.
- 3 Year Warranty, Customer Support and Service in the USA

Electric Chain Hoist Description

This 1/4-ton electric chain hoist features a power trolley for smooth horizontal movement and variable speed control for precise lifting. It operates on a 380V 3-phase 50~60Hz power supply, offering reliable and efficient performance for light-duty industrial applications that require flexibility and precision.

Technical Specifications

Rated Load Capacity	1/4 ton	Transmission / Reducer Type	Spur gearbox
Standard Lifting Height	13 ft / 4 m	Load Chain Type	G100 Nikel
Speed (f/m) / min	ft @60Hz 1.5~9.6 mt @50Hz	Load Chain Size	5mm
Number of Speeds	Variable Speed	Chain Falls	1
Capacity Range	13	Chain Length	13 ft (4 m)
Voltage	3 Phase 380V 50Hz	Humidity	20%~90%
Total Power Watts	1500	Temperature	-4 ~ 104° F / -20 ~ 40° C
Duty Class	H4/M5/2m/Class D	Trolley Power	250
IEC Motor Protection	IP55	Trolley Speed /min	5.9~47.23 ft @60Hz 1.5~12 mt @50Hz
Control	Pendant Control IP66 and Optional Wireless	Trolley Number of Speeds	Variable
Control Voltage	24V	Standards Compliance	ASME HST-1 , ASME B30.16 , EN60204-36
Emergency Stop	Yes	Warranty	3 Year

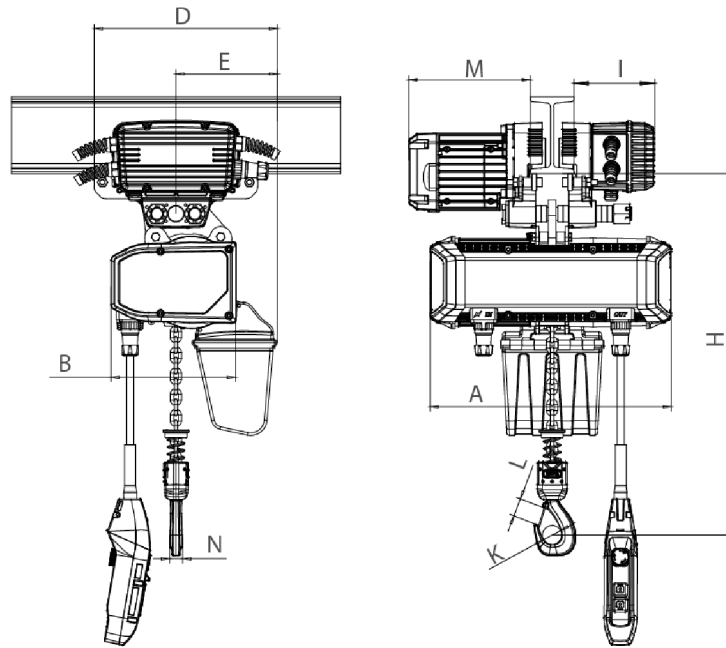

Rated load (t)	Type	Dimension (mm)									
		Minimum distance from the bottom of the track to the bottom hook: H	A	L	B	D	E	I	M	N	K
0.25-0.5	PWRXT0.25-0.5-VS	473	447	3500-5500	217	334	152	147	220	20	35

Unit Weight & Dimensions

H Minimum Headroom	385
W Width	305
A Total Height	385
J Hook Opening	35

Packaging Weight & Dimensions

Package 1 Net Weight	72.16 lbs / 33 Kg
Package 2 Net Weight	62.48 lbs / 28 Kg
Package 1 Gross Weight	85.8 lbs / 39 Kg
Package 2 Gross Weight	70.4 lbs / 32 Kg

D Depth	440	Package 1 Length	20 in / 50.8 cm
Total Weight (w/out cable or Chain)	67	Package 2 Length	8 in / 20.32 cm
Total Unit Weight	134.64 lbs / 62 Kg	Package 1 Width	15 in / 38.1 cm
		Package 2 Width	13 in / 33.02 cm
		Package 1 Height	20 in / 50.8 cm
		Package 2 Height	20 in / 50.8 cm