



## 1/4 ton Electric Chain Hoist w/ Power Trolley Variable Speed 220V 1ø 50~60HZ 13ft G100 Nickel Duty H4/M5

### Key features

- Capacity: Lifts up to 1/4 ton (approximately 500 lbs)
- Power Supply: 220V single-phase, compatible with 50~60Hz
- Speed Control: Variable speed operation for precise lifting and lowering
- 3 Year Warranty, Customer Support and Service in the USA

### Electric Chain Hoist Description

The 1/4 Ton Electric Chain Hoist with Power Trolley is a robust and efficient lifting solution designed for heavy-duty applications. Featuring variable speed control, this hoist allows for precise handling of loads up to 500 lbs. With a 220V single-phase power supply compatible with both 50 and 60Hz, it ensures versatility in various settings. The 13 ft G100 nickel-plated chain enhances durability, while the integrated power trolley enables smooth horizontal movement. With an H4/M5 duty cycle rating, this hoist is built for frequent and reliable use.

## Technical Specifications

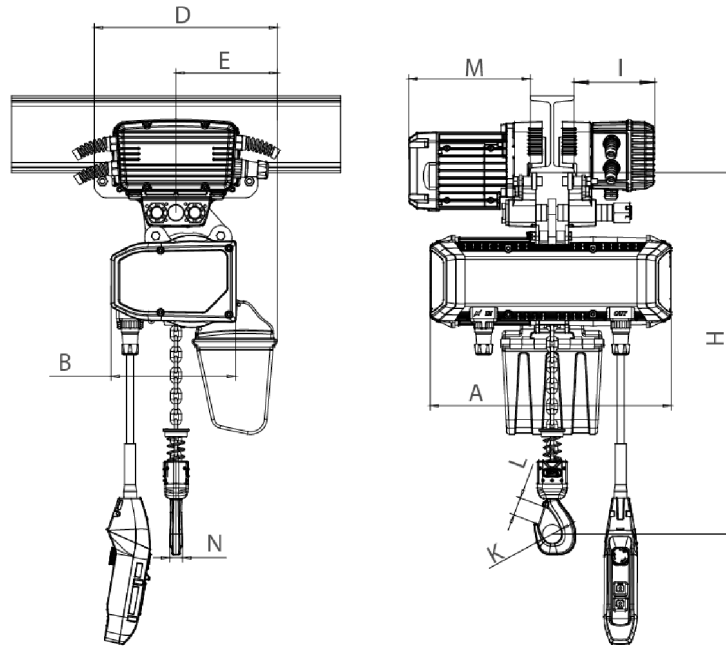

Rated load (t)	Type	Dimension (mm)									
		Minimum distance from the bottom of the track to the bottom hook: H	A	L	B	D	E	I	M	N	K
0.25-0.5	PWRXT0.25-0.5-VS	473	447	3500-5500	217	334	152	147	220	20	35

## Unit Weight & Dimensions

Total Unit Weight

134.64 lbs / 62 Kg