



## **1/4 ton Electric Chain Hoist w/ Power Trolley Variable Speed 110V 1ø 60HZ 13ft G100 Nickel Duty H4/M5**

### **Key features**

- Capacity: Lifts up to 1/4 ton (approximately 500 lbs)
- Power Supply: 110V single-phase, 60Hz for easy compatibility
- Speed Control: Variable speed operation for accurate lifting and lowering
- 3 Year Warranty, Customer Support and Service in the USA

### **Electric Chain Hoist Description**

The 1/4 Ton Electric Chain Hoist with Power Trolley is a versatile and efficient lifting solution designed for a variety of applications. Featuring variable speed control, this hoist allows for precise handling of loads up to 500 lbs. With a 110V single-phase power supply operating at 60Hz, it's suitable for both industrial and commercial settings. The integrated power trolley ensures smooth horizontal movement, making it ideal for tasks that require flexibility and precision.

## Technical Specifications

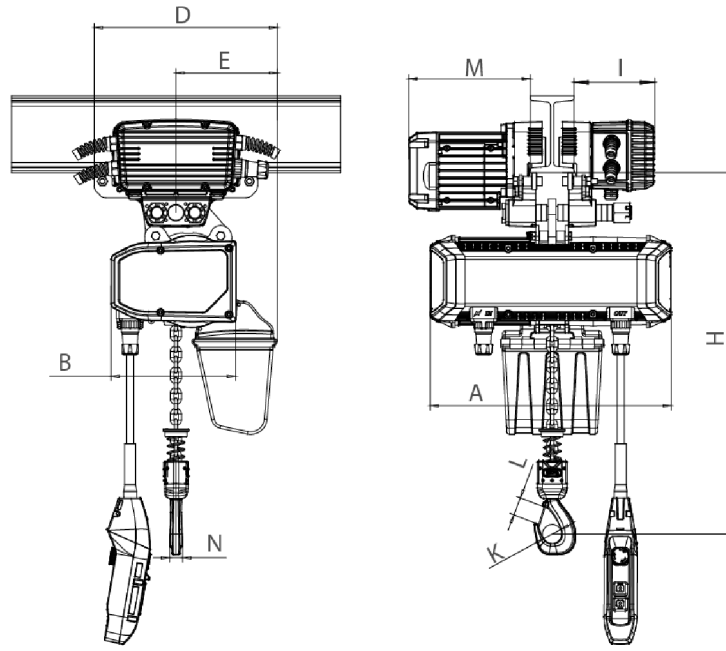

Rated load (t)	Type	Dimension (mm)									
		Minimum distance from the bottom of the track to the bottom hook: H	A	L	B	D	E	I	M	N	K
0.25-0.5	PWRXT0.25-0.5-VS	473	447	3500-5500	217	334	152	147	220	20	35

## Unit Weight & Dimensions

Total Unit Weight

134.64 lbs / 62 Kg