

7.5 ton Electric Chain Hoist Variable Speed 380V 3ø 50~60HZ 30ft G100 Nickel Duty H4/M5

Key features

- Heavy Duty H4/M5 US and EC Standards ASME HST-1 , ASME B30.16 , EN14492-2 , EN60204-32
- Patented Overload Motor Slip Protection with Heavy Duty Electromagnetic Disk Brake
- Variable Speed Inverter with Potentiometer for Precise Control, Dual System Limit Switches, Emergency Stop
- Super Heavy Duty G100 Nickel Chain, 25% Stronger than G80. Standard ASTM A973
- 3 Year Warranty, Customer Support and Service in the USA

7.5 ton Electric Chain Hoist Variable Speed 380V 3ø 50~60HZ

Technical Specifications

Rated Load Capacity	7.5 ton	Total Power Watts	4000
Capacity Range	7	Power Cord Length and Phase Order	3 ft / Red L1, White L2 and Black L3, Green ground
Voltage	3 Phase 380V 50Hz	Recommended Hoist Protection Circuit Breaker AMPs and Type	Type D 20A
Standard Lifting Height	30 ft / 9 m	Optional Load Chain Brand & Country of Origin	FEC Japan
Speed (f/m) / min	ft @60Hz 0.3~1.8 mt @50Hz	Load Chain Type	G100 Nikel
Number of Speeds	Variable Speed	Load Chain Size	11.2 mm
Hoist VFD Power	4kW	Chain Falls	3
Hoist VFD Brand	HUAYUAN	Chain Length	90
VFD Model	Z230	Load Chain weight per foot [lbs]	1.83
Brake Resistor Kw	1Kw	Humidity	20%~90%
Duty Class	H4/M5/2m/Class D	Temperature	-4 ~ 104° F / -20 ~ 40° C
IEC Hoist IP Protection	IP55	Transmission / Reducer Type	Spur gearbox
IEC Motor Protection	IP55	Reducer Lubrication Type	Oil
Pendant Control Yes No	Yes	Paint Specifications	Electrostatic Sprayed Plastic (ESP) Epoxy resins, Polyester Resins, Barium, Pigments
IEC Pendant Control Protection	IP66	Standards Compliance	ASME HST-1 , ASME B30.16 , EN60204-37
Pendant Control Emergency Stop	Yes	Standards Certified	CE
Pendant Control total Length	27 ft	Overload Protection	Overload Motor Clutch
Hoist Motor Power in KW	3	Hour Meter	Internal Working Hour Meter
Hoist Motor Brake Type and DC Voltage	DC170V	Brake SKU	PWRX-2-20-PN.60.61
Hoist Motor Insulation Grade	F	Brake rectifiers-half-wave	PWRX-BKTF-HW

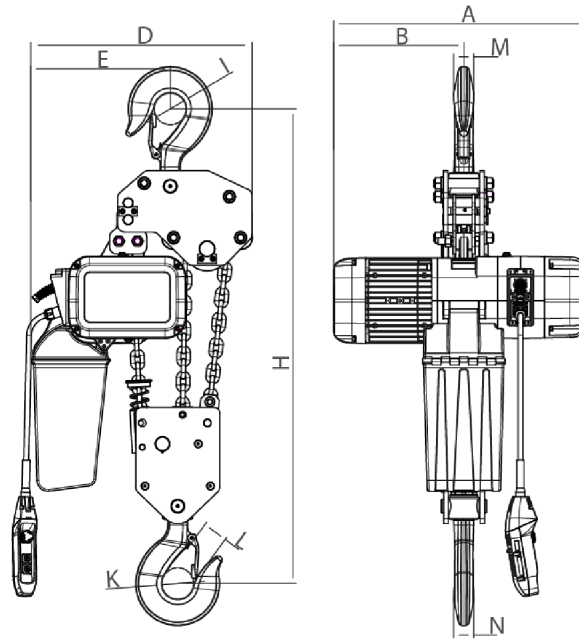

[Size list: mm]

Rated load (t)	Type	Minimum distance between hooks: H	A	B	D	E	I	M	N	K	L
7	PWRXF7-03	1170	695	350	420	265	45	20	34	59	48

Unit Weight & Dimensions

A Total Height	1020
J Hook Opening	85
W Width	576
H Minimum Headroom	1170
D Depth	681
1st Package Type	Wood Crate
Total Weight (w/out cable or Chain)	130
Total Unit Weight	294.8 lbs / 134 Kg

Packaging Weight & Dimensions

Package 1 Height	31 in / 78.74 cm
Package 1 Net Weight	294.8 lbs / 134 Kg
Package 1 Width	20 in / 50.8 cm
Package 1 Gross Weight	495 lbs / 225 Kg
Package 1 Length	30 in / 76.2 cm