

7.5 ton Electric Chain Hoist Variable Speed 440~480V 3Ø 50~60HZ 30ft G100 Nickel Duty H4/M5

Key features

- Heavy Duty H4/M5 US and EC Standards ASME HST-1 , ASME B30.16 , EN14492-2 , EN60204-32
- Patented Overload Motor Slip Protection with Heavy Duty Electromagnetic Disk Brake
- Variable Speed Inverter with Potentiometer for Precise Control, Dual System Limit Switches, Emergency Stop
- Super Heavy Duty G100 Nickel Chain, 25% Stronger than G80. Standard ASTM A973
- 3 Year Warranty, Customer Support and Service in the USA

7.5 ton Electric Chain Hoist Variable Speed 440~480V 3Ø 50~60HZ

Our Dedication to Excellence:

At Prowinch, our unwavering commitment to delivering the best price-performance ratio is evident in every Electric Chain Hoist we produce. We subject each unit to meticulous testing and continuously enhance key components, considering factors that influence lifespan. This commitment ensures that we consistently provide a superior product at an optimal price point.

Enhanced Components:

Internally, each component has undergone substantial upgrades to meet the highest quality standards. Key electronic parts are carefully sourced from reputable brands, while locally manufactured lubricants are employed to fortify the durability of gears and reducers. The final assembly and testing processes take place in the US, guaranteeing that every unit surpasses corresponding standards.

Variable Speed Innovation:

Designed for unparalleled control, our Variable Speed Electric Chain Hoist offers a dynamic lifting experience. Ideal for applications requiring precise load positioning, this hoist allows you to adjust lifting speeds according to the specific needs of your project.

Duty Classification:

Choosing the right unit is pivotal, and our M5-rated H4 hoists stand out for their excellence in high-volume handling. Tailored for environments like steel warehouses, machine shops, fabricating plants, and mills, these hoists boast a 50% maximum operational time per hour for uniformly distributed work periods. They can efficiently handle up to 300 starts per hour. In scenarios of infrequent work periods, the hoist can operate for 30 minutes from a cold start with up to 300 starts per hour. Operational time ratings adhere to a 65% load factor, following ASME HST-1-2012 guidelines.

Control System:

The Variable Speed Electric Chain Hoist is equipped with an advanced control system, allowing for precise speed adjustments tailored to your lifting requirements. The standard pendant control, designed with a length 4 feet less than the lifting height, ensures easy operation from ground level. For added convenience, an optional wireless control is available.

Advanced Braking System:

Our hoists feature an electromagnetic brake system, rigorously tested at 125% of the hoist capacity. This system is intelligently designed to engage automatically upon any loss of power, ensuring not only enhanced safety but also precise control over the operation of the hoist.

Technical Specifications

Rated Load Capacity	7.5 ton	Total Power Watts	4000
Capacity Range	7	Power Cord Length and Phase Order	3 ft / Black L1 , Red L2 and Blue L3 Green ground
Voltage	3 Phase 440~480V 60Hz	Recommended Hoist Protection Circuit Breaker AMPs and Type	Type D 20A
Standard Lifting Height	30 ft / 9 m	Optional Load Chain Brand & Country of Origin	FEC Japan
Speed (f/m) / min	1.1~7 ft @60Hz mt @50Hz	Load Chain Type	G100 Nikel
Number of Speeds	Variable Speed	Load Chain Size	11.2 mm
Hoist VFD Power	4kW	Chain Falls	3
Hoist VFD Brand	HUAYUAN	Chain Length	90
VFD Model	Z230	Load Chain weight per foot [lbs]	1.83
Brake Resistor Kw	1Kw	Humidity	20%~90%
Duty Class	H4/M5/2m/Class D	Temperature	-4 ~ 104° F / -20 ~ 40° C
IEC Hoist IP Protection	IP55	Transmission / Reducer Type	Spur gearbox
IEC Motor Protection	IP55	Reducer Lubrication Type	Oil
Pendant Control Yes No	Yes	Paint Specifications	Electrostatic Sprayed Plastic (ESP) Epoxy resins, Polyester Resins, Barium, Pigments
IEC Pendant Control Protection	IP66	Standards Compliance	ASME HST-1 , ASME B30.16 , EN60204-37
Pendant Control Emergency Stop	Yes	Standards Certified	CE
Pendant Control total Length	27 ft	Overload Protection	Overload Motor Clutch
Hoist Motor Power in KW	3	Hour Meter	Internal Working Hour Meter
Hoist Motor Brake Type and DC Voltage	DC207V	Brake SKU	PWRX-2-20-PN.60.61
Hoist Motor Insulation Grade	F	Brake rectifiers-half-wave	PWRX-BKTF-HW

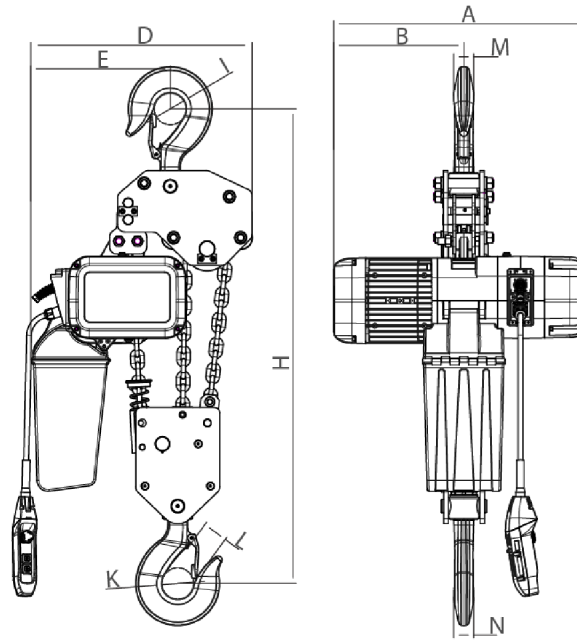

[Size list: mm]

Rated load (t)	Type	Minimum distance between hooks: H	A	B	D	E	I	M	N	K	L
7	PWRXF7-03	1170	695	350	420	265	45	20	34	59	48

Unit Weight & Dimensions

A Total Height	1020
J Hook Opening	85
W Width	576
H Minimum Headroom	1170
D Depth	681
1st Package Type	Wood Crate
Total Weight (w/out cable or Chain)	130
Total Unit Weight	294.8 lbs / 134 Kg

Packaging Weight & Dimensions

Package 1 Height	31 in / 78.74 cm
Package 1 Net Weight	294.8 lbs / 134 Kg
Package 1 Width	20 in / 50.8 cm
Package 1 Gross Weight	495 lbs / 225 Kg
Package 1 Length	30 in / 76.2 cm