



## 5 ton Electric Chain Hoist Variable Speed 380V 3ø 50~60HZ 30ft G100 Nickel Duty H4/M5

### Key features

- Lifting Capacity: 5 tons (10,000 lbs)
- Power Supply: 380V, 3-phase, 50~60Hz
- Speed Control: Variable speed for precise lifting and positioning
- 3 Year Warranty, Customer Support and Service in the USA

### Electric Chain Hoist Description

The 5 Ton Electric Chain Hoist with variable speed control is designed for precision lifting in various industrial applications. With a lifting capacity of 5 tons, this hoist operates on 380V, 3-phase, 50~60Hz power, making it suitable for diverse operational environments. The variable speed feature allows for smooth and accurate lifting, ensuring optimal positioning for heavy loads. Built for durability and equipped with essential safety mechanisms, this hoist is perfect for demanding work conditions.

## Technical Specifications

<b>Rated Load Capacity</b>	5 ton	<b>Chain Falls</b>	2
<b>Standard Lifting Height</b>	30 ft / 9 m	<b>Chain Length</b>	60
<b>Speed (f/m) / min</b>	ft @60Hz 0.4~2.7 mt @50Hz	<b>Humidity</b>	20%~90%
<b>Number of Speeds</b>	Variable Speed	<b>Temperature</b>	-4 ~ 104° F / -20 ~ 40° C
<b>Voltage</b>	3 Phase 380V 50Hz	<b>Standards Compliance</b>	ASME HST-1 , ASME B30.16 , EN60204-36
<b>Total Power Watts</b>	4000	<b>Warranty</b>	3 Year
<b>Duty Class</b>	H4/M5/2m/Class D	<b>Hoist VFD Power</b>	4kW
<b>IEC Motor Protection</b>	IP55	<b>Hoist VFD Brand</b>	HUAYUAN
<b>Control</b>	Pendant Control IP66 and Optional Wireless	<b>Hoist Motor Power in KW</b>	3
<b>Control Voltage</b>	24V	<b>Hour Meter</b>	Internal Working Hour Meter
<b>Emergency Stop</b>	Yes	<b>Hoist Motor Insulation Grade</b>	F
<b>Transmission / Reducer Type</b>	Spur gearbox	<b>IEC Hoist IP Protection</b>	IP55
<b>Load Chain Type</b>	G100 Nickel	<b>IEC Pendant Control Protection</b>	IP66
<b>Load Chain Size</b>	11.2 mm	<b>Hoist Motor Brake Type and DC Voltage</b>	DC170V

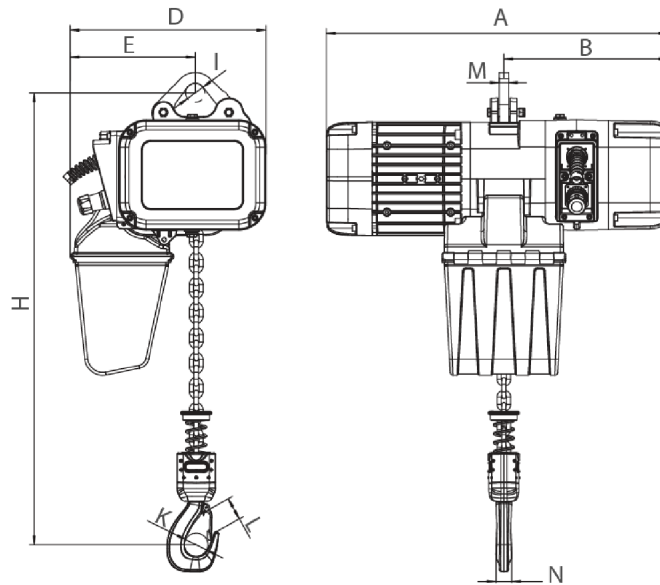

[Size list: mm]

Rated load (t)	Type	Minimum distance between hooks: H	A	B	D	E	I	M	N	K	L
1	PWRXF1-01	455	590	276	330	210	32	16	25	42	32
2	PWRXF2-01	550	590	276	330	210	38	20	35	52	42
3	PWRXF3-01	560	695	350	420	265	45	20	34	59	48
5	PWRXF5-02	675	695	350	420	307	55	28	44	60	48

## Unit Weight & Dimensions

<b>H Minimum Headroom</b>	810
<b>J Hook Opening</b>	60
<b>A Total Height</b>	675
<b>Total Weight (w/out cable or Chain)</b>	185
<b>D Depth</b>	695
<b>1st Package Type</b>	Wood Crate
<b>W Width</b>	420

## Packaging Weight & Dimensions

<b>Package 1 Net Weight</b>	294.8 lbs / 134 Kg
<b>Package 1 Width</b>	20 in / 50.8 cm
<b>Package 1 Gross Weight</b>	495 lbs / 225 Kg
<b>Package 1 Height</b>	31 in / 78.74 cm
<b>Package 1 Length</b>	30 in / 76.2 cm

**Total Unit Weight**

294.8 lbs / 134 Kg