



5 ton Electric Chain Hoist 2 Speed 575V 3ø 50/60HZ 30ft G100 Nickel Duty H4/M5

Key features

- Load Capacity: Lifts up to 5 tons (11,000 lbs.), designed for heavy industrial lifting operations.
- Voltage: Operates on a 575V, 3-phase power supply, with a tolerance of -10% voltage variation, suitable for areas with both 50Hz and 60Hz power frequencies.
- Speed: Dual-speed functionality for both precise and fast lifting, allowing efficient control over the lifting process.
- 3 Year Warranty, Customer Support and Service in the USA

Electric Chain Hoist Description

This 5-ton electric chain hoist features dual speed control for flexible lifting operations. Designed to operate on a 575V $\pm 10\%$ 3-phase 50/60Hz power supply, it offers reliable performance for heavy-duty industrial applications. Its robust design ensures durability and efficiency, making it ideal for demanding lifting tasks.

Our Dedication to Excellence:

At Prowinch, our unwavering commitment to delivering the best price-performance ratio is evident in every Electric Chain Hoist we produce. We subject each unit to meticulous testing and continuously enhance key components, considering factors that influence lifespan. This commitment ensures that we consistently provide a superior product at an optimal price point.

Enhanced Components:

Internally, each component has undergone substantial upgrades to meet the highest quality standards. Key electronic parts are carefully sourced from reputable brands, while locally manufactured lubricants are employed to fortify the durability of gears and reducers. The final assembly and testing processes take place in the US, guaranteeing that every unit surpasses corresponding standards.

Double Speed Precision:

Our Double Speed Electric Chain Hoist is engineered for versatility in lifting operations. Offering both high and low-speed options, this hoist provides precision and adaptability, making it suitable for a wide range of applications.

Duty Classification:

Choosing the right unit is pivotal, and our M5-rated H4 hoists stand out for their excellence in high-volume handling. Tailored for environments like steel warehouses, machine shops, fabricating plants, and mills, these hoists boast a 50% maximum operational time per hour for uniformly distributed work periods. They can efficiently handle up to 300 starts per hour. In scenarios of infrequent work periods, the hoist can operate for 30 minutes from a cold start with up to 300 starts per hour. Operational time ratings adhere to a 65% load factor, following ASME HST-1-2012 guidelines.

Control System:

The Double Speed Electric Chain Hoist features an advanced control system, providing flexibility with both high and low-speed options. The standard pendant control, designed with a length 4 feet less than the lifting height, ensures easy operation from ground level. For added convenience, an optional wireless control is available.

Advanced Braking System:

Our hoists feature an electromagnetic brake system, rigorously tested at 125% of the hoist capacity. This system is intelligently designed to engage automatically upon any loss of power, ensuring not only enhanced safety but also precise control over the operation of the hoist.

Technical Specifications

Rated Load Capacity	5 ton	Power Cord Length and Phase Order	3 ft / Red L1, White L2 and Black L3, Green ground
Capacity Range	6	Recommended Hoist Protection Circuit Breaker AMPs and Type	Type D 20A
Voltage	3 Phase 575v 50/60hz	Optional Load Chain Brand & Country of Origin	FEC Japan
Standard Lifting Height	30 ft / 9 m	Load Chain Type	G100 Nikel
Speed (f/m) / min	3.1/10.6 ft @60Hz 0.8/2.7 mt @50Hz	Load Chain Size	11.2 mm
Number of Speeds	2 Speed	Chain Falls	2
Hoist Contactors Amps	25A	Chain Length	60
Hoist Contactor Brand	Schneider	Load Chain weight per foot [lbs]	1.83
Hoist Contactor Coil Voltage	24 V	Humidity	20%~90%
Duty Class	H4/M5/2m/Class D	Temperature	-4 ~ 104° F / -20 ~ 40° C
IEC Hoist IP Protection	IP55	Transmission / Reducer Type	Spur gearbox
IEC Motor Protection	IP55	Reducer Lubrication Type	Oil
Pendant Control Yes No	Yes	Paint Specifications	Electrostatic Sprayed Plastic (ESP) Epoxy resins, Polyester Resins, Barium, Pigments
IEC Pendant Control Protection	IP66	Standards Compliance	ASME HST-1 , ASME B30.16 , EN60204-36
Pendant Control Emergency Stop	Yes	Standards Certified	CE
Pendant Control total Length	27 ft	Overload Protection	Overload Motor Clutch
Hoist Motor Power in KW	3	Hour Meter	Internal Working Hour Meter
Hoist Motor Brake Type and DC Voltage	DC260V	Brake SKU	PWRX-2-20-PN.60.61
Hoist Motor Insulation Grade	F	Brake rectifiers-half-wave	PWRX-BKTF-HW
Total Power Watts	3000		

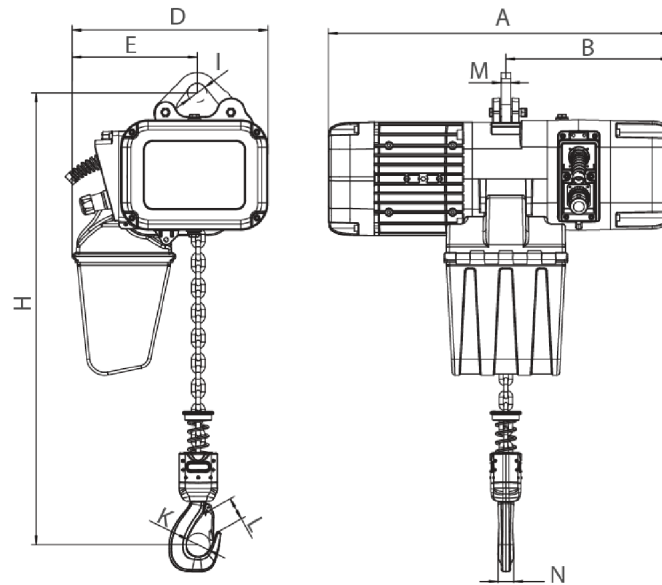

[Size list: mm]

Rated load (t)	Type	Minimum distance between hooks: H	A	B	D	E	I	M	N	K	L
1	PWRXF1-01	455	590	276	330	210	32	16	25	42	32
2	PWRXF2-01	550	590	276	330	210	38	20	35	52	42
3	PWRXF3-01	560	695	350	420	265	45	20	34	59	48
5	PWRXF5-02	675	695	350	420	307	55	28	44	60	48

Unit Weight & Dimensions

A Total Height	675
J Hook Opening	60
W Width	420
H Minimum Headroom	810
D Depth	695
1st Package Type	Wood Crate
Total Weight (w/out cable or Chain)	185

Packaging Weight & Dimensions

Package 1 Height	31 in / 78.74 cm
Package 1 Net Weight	294.8 lbs / 134 Kg
Package 1 Width	20 in / 50.8 cm
Package 1 Gross Weight	495 lbs / 225 Kg
Package 1 Length	30 in / 76.2 cm

Total Unit Weight

294.8 lbs / 134 Kg