



5 ton Electric Chain Hoist 2 Speed 208~240V / 440~480V 3ø 60HZ 30ft G100 Nickel Duty H4/M5

Key features

- Lifting Capacity: 5 tons (10,000 lbs)
- Power Supply Options: 208~240V or 440~480V, 3-phase, 60Hz
- Speed Options: Two-speed operation for enhanced control and precision
- 3 Year Warranty, Customer Support and Service in the USA

Electric Chain Hoist Description

The 5 Ton Electric Chain Hoist with dual speed functionality is designed for versatility and efficiency in heavy lifting applications. Capable of lifting up to 5 tons, this hoist operates on dual voltage options of 208~240V / 440~480V, 3-phase, 60Hz. Its two-speed operation allows for precise control during lifting, making it ideal for a wide range of industrial tasks. Built for durability and equipped with essential safety features, this hoist is perfect for demanding environments.

Our Dedication to Excellence:

At Prowinch, our unwavering commitment to delivering the best price-performance ratio is evident in every Electric Chain Hoist we produce. We subject each unit to meticulous testing and continuously enhance key components, considering factors that influence lifespan. This commitment ensures that we consistently provide a superior product at an optimal price point.

Enhanced Components:

Internally, each component has undergone substantial upgrades to meet the highest quality standards. Key electronic parts are carefully sourced from reputable brands, while locally manufactured lubricants are employed to fortify the durability of gears and reducers. The final assembly and testing processes take place in the US, guaranteeing that every unit surpasses corresponding standards.

Double Speed Precision:

Our Double Speed Electric Chain Hoist is engineered for versatility in lifting operations. Offering both high and low-speed options, this hoist provides precision and adaptability, making it suitable for a wide range of applications.

Duty Classification:

Choosing the right unit is pivotal, and our M5-rated H4 hoists stand out for their excellence in high-volume handling. Tailored for environments like steel warehouses, machine shops, fabricating plants, and mills, these hoists boast a 50% maximum operational time per hour for uniformly distributed work periods. They can efficiently handle up to 300 starts per hour. In scenarios of infrequent work periods, the hoist can operate for 30 minutes from a cold start with up to 300 starts per hour. Operational time ratings adhere to a 65% load factor, following ASME HST-1-2012 guidelines.

Control System:

The Double Speed Electric Chain Hoist features an advanced control system, providing flexibility with both high and low-speed options. The standard pendant control, designed with a length 4 feet less than the lifting height, ensures easy operation from ground level. For added convenience, an optional wireless control is available.

Advanced Braking System:

Our hoists feature an electromagnetic brake system, rigorously tested at 125% of the hoist capacity. This system is intelligently designed to engage automatically upon any loss of power, ensuring not only enhanced safety but also precise control over the operation of the hoist.

Technical Specifications

Rated Load Capacity	5 ton	Chain Falls	2
Standard Lifting Height	30 ft / 9 m	Chain Length	60
Speed (f/m) / min	10.63 ft @60Hz 2.70 mt @50Hz	Humidity	20%~90%
Number of Speeds	2 Speed	Temperature	-4 ~ 104° F / -20 ~ 40° C
Capacity Range	6	Standards Compliance	ASME HST-1 , ASME B30.16 , EN60204-36
Voltage	3 Phase 208~240/440~480V 50/60Hz	Warranty	3 Year
Total Power Watts	3000	Hoist Motor Power in KW	3
Duty Class	H4/M5/2m/Class D	Hour Meter	Internal Working Hour Meter
IEC Motor Protection	IP55	Hoist Motor Insulation Grade	F
Control	Pendant Control IP66 and Optional Wireless	Hoist Contactor Coil Voltage	24 V
Control Voltage	24V	Hoist Contactors Amps	25A
Emergency Stop	Yes	Hoist Contactor Brand	Schneider
Transmission / Reducer Type	Spur gearbox	IEC Hoist IP Protection	IP55
Load Chain Type	G100 Nickel	IEC Pendant Control Protection	IP66
Load Chain Size	11.2 mm	Hoist Motor Brake Type and DC Voltage	DC99V/DC207V

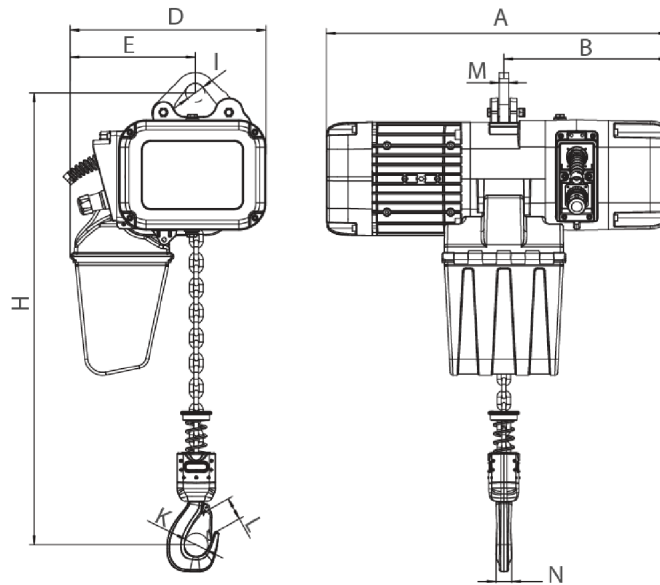

[Size list: mm]

Rated load (t)	Type	Minimum distance between hooks: H	A	B	D	E	I	M	N	K	L
1	PWRXF1-01	455	590	276	330	210	32	16	25	42	32
2	PWRXF2-01	550	590	276	330	210	38	20	35	52	42
3	PWRXF3-01	560	695	350	420	265	45	20	34	59	48
5	PWRXF5-02	675	695	350	420	307	55	28	44	60	48

Unit Weight & Dimensions

H Minimum Headroom	810
J Hook Opening	60
A Total Height	675
Total Weight (w/out cable or Chain)	185
D Depth	695
1st Package Type	Wood Crate
W Width	420

Packaging Weight & Dimensions

Package 1 Net Weight	294.8 lbs / 134 Kg
Package 1 Width	20 in / 50.8 cm
Package 1 Gross Weight	495 lbs / 225 Kg
Package 1 Height	31 in / 78.74 cm
Package 1 Length	30 in / 76.2 cm

Total Unit Weight

294.8 lbs / 134 Kg