



3 ton Electric Chain Hoist Variable Speed 220V 1ø 50~60HZ

3 ton Electric Chain Hoist Variable Speed 220V 1ø 50~60HZ

Technical Specifications

Rated Load Capacity	3 ton	Hoist Motor Brake Type and DC Voltage	DC170V
Capacity Range	5	Hoist Motor Insulation Grade	F
Voltage	1 Phase 220~240V 50/60Hz	Total Power Watts	4000
Standard Lifting Height	30 ft / 9 m	Power Cord Length and Phase Order	3 ft / Black L1, White, Green ground
Speed (f/m) / min	ft @60Hz 0.7~5.4 mt @50Hz	Recommended Hoist Protection Circuit Breaker AMPs and Type	Type D 20A
Number of Speeds	Variable Speed	Optional Load Chain Brand & Country of Origin	FEC Japan
Hoist VFD Power	4kW	Load Chain Type	G100 Nikel
Hoist VFD Brand	HUAYUAN	Load Chain Size	11.2 mm
VFD Model	Z230	Chain Falls	1
Brake Resistor Kw	1Kw	Chain Length	30
Duty Class	H4/M5/2m/Class D	Load Chain weight per foot [lbs]	1.83
IEC Hoist IP Protection	IP55	Humidity	20%~90%
IEC Motor Protection	IP55	Temperature	-4 ~ 104° F / -20 ~ 40° C
Pendant Control Yes No	Yes	Transmission / Reducer Type	Spur gearbox
IEC Pendant Control Protection	IP66	Reducer Lubrication Type	Oil
Pendant Control Emergency Stop	Yes	Paint Specifications	Electrostatic Sprayed Plastic (ESP) Epoxy resins, Polyester Resins, Barium, Pigments
Pendant Control total Length	27 ft	Standards Compliance	ASME HST-1 , ASME B30.16 , EN60204-35
Hoist Motor Power in KW	3	Standards Certified	CE

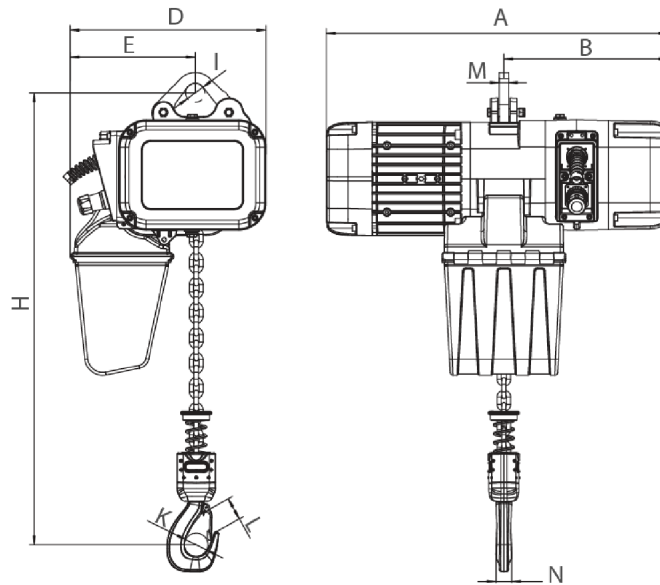

[Size list: mm]

Rated load (t)	Type	Minimum distance between hooks: H	A	B	D	E	I	M	N	K	L
1	PWRXF1-01	455	590	276	330	210	32	16	25	42	32
2	PWRXF2-01	550	590	276	330	210	38	20	35	52	42
3	PWRXF3-01	560	695	350	420	265	45	20	34	59	48
5	PWRXF5-02	675	695	350	420	307	55	28	44	60	48

Unit Weight & Dimensions

A Total Height	560
J Hook Opening	59
W Width	420
H Minimum Headroom	645
D Depth	695
1st Package Type	Wood Crate
Total Weight (w/out cable or Chain)	130

Packaging Weight & Dimensions

Package 1 Height	31 in / 78.74 cm
Package 1 Net Weight	184.8 lbs / 84 Kg
Package 1 Width	20 in / 50.8 cm
Package 1 Gross Weight	330 lbs / 150 Kg
Package 1 Length	30 in / 76.2 cm

Total Unit Weight

184.8 lbs / 84 Kg