



3 ton Electric Chain Hoist 2 Speed 208~240V / 440~480V 3ø 60HZ 30ft G100 Nickel Duty H4/M5

Key features

- Lifting Capacity: 3 tons (6,000 lbs)
- Power Supply Options: 208240V or 440480V, 3-phase, 60Hz
- Speed Options: Two-speed operation for enhanced control and precision
- 3 Year Warranty, Customer Support and Service in the USA

Electric Chain Hoist Description

The 3 Ton Electric Chain Hoist with dual speed functionality is designed for versatile and efficient lifting in industrial applications. Capable of lifting up to 3 tons, this hoist operates on dual voltage options of 208240V and 440480V, 3-phase, 60Hz. Its two-speed operation allows for precise control and handling, making it ideal for various heavy lifting tasks. Built for durability and equipped with essential safety features, this hoist is perfect for demanding environments.

Our Dedication to Excellence:

At Prowinch, our unwavering commitment to delivering the best price-performance ratio is evident in every Electric Chain Hoist we produce. We subject each unit to meticulous testing and continuously enhance key components, considering factors that influence lifespan. This commitment ensures that we consistently provide a superior product at an optimal price point.

Enhanced Components:

Internally, each component has undergone substantial upgrades to meet the highest quality standards. Key electronic parts are carefully sourced from reputable brands, while locally manufactured lubricants are employed to fortify the durability of gears and reducers. The final assembly and testing processes take place in the US, guaranteeing that every unit surpasses corresponding standards.

Double Speed Precision:

Our Double Speed Electric Chain Hoist is engineered for versatility in lifting operations. Offering both high and low-speed options, this hoist provides precision and adaptability, making it suitable for a wide range of applications.

Duty Classification:

Choosing the right unit is pivotal, and our M5-rated H4 hoists stand out for their excellence in high-volume handling. Tailored for environments like steel warehouses, machine shops, fabricating plants, and mills, these hoists boast a 50% maximum operational time per hour for uniformly distributed work periods. They can efficiently handle up to 300 starts per hour. In scenarios of infrequent work periods, the hoist can operate for 30 minutes from a cold start with up to 300 starts per hour. Operational time ratings adhere to a 65% load factor, following ASME HST-1-2012 guidelines.

Control System:

The Double Speed Electric Chain Hoist features an advanced control system, providing flexibility with both high and low-speed options. The standard pendant control, designed with a length 4 feet less than the lifting height, ensures easy operation from ground level. For added convenience, an optional wireless control is available.

Advanced Braking System:

Our hoists feature an electromagnetic brake system, rigorously tested at 125% of the hoist capacity. This system is intelligently designed to engage automatically upon any loss of power, ensuring not only enhanced safety but also precise control over the operation of the hoist.

Technical Specifications

| | | | |
|--|----------------------------------|---|---|
| Rated Load Capacity | 3 ton | Power Cord Length and Phase Order | 3 ft / Black L1 , Red L2 and Blue L3 Green ground |
| Capacity Range | 4 | Recommended Hoist Protection Circuit Breaker AMPs and Type | Type D 25A at 220V and 20A at 460V |
| Voltage | 3 Phase 208~240/440~480V 50/60Hz | Optional Load Chain Brand & Country of Origin | FEC Japan |
| Standard Lifting Height | 30 ft / 9 m | Load Chain Type | G100 Nikel |
| Speed (f/m) / min | 21.26 ft @60Hz 5.40 mt @50Hz | Load Chain Size | 11.2 mm |
| Number of Speeds | 2 Speed | Chain Falls | 1 |
| Hoist Contactors Amps | 25A | Chain Length | 30 |
| Hoist Contactor Brand | Schneider | Load Chain weight per foot [lbs] | 1.83 |
| Hoist Contactor Coil Voltage | 24 V | Humidity | 20%~90% |
| Duty Class | H4/M5/2m/Class D | Temperature | -4 ~ 104° F / -20 ~ 40° C |
| IEC Hoist IP Protection | IP55 | Transmission / Reducer Type | Spur gearbox |
| IEC Motor Protection | IP55 | Reducer Lubrication Type | Oil |
| Pendant Control Yes No | Yes | Paint Specifications | Electrostatic Sprayed Plastic (ESP) Epoxy resins, Polyester Resins, Barium, Pigments |
| IEC Pendant Control Protection | IP66 | Standards Compliance | ASME HST-1 , ASME B30.16 , EN60204-35 |
| Pendant Control Emergency Stop | Yes | Standards Certified | CE |
| Pendant Control total Length | 27 ft | Overload Protection | Overload Motor Clutch |
| Hoist Motor Power in KW | 3 | Hour Meter | Internal Working Hour Meter |
| Hoist Motor Brake Type and DC Voltage | DC99V/DC207V | Brake SKU | PWRX-2-20-PN.60.61 |
| Hoist Motor Insulation Grade | F | Brake rectifiers-half-wave | PWRX-BKTF-HW |
| Total Power Watts | 3000 | Brake rectifiers-full-wave | PWRX-BKTF-FW |

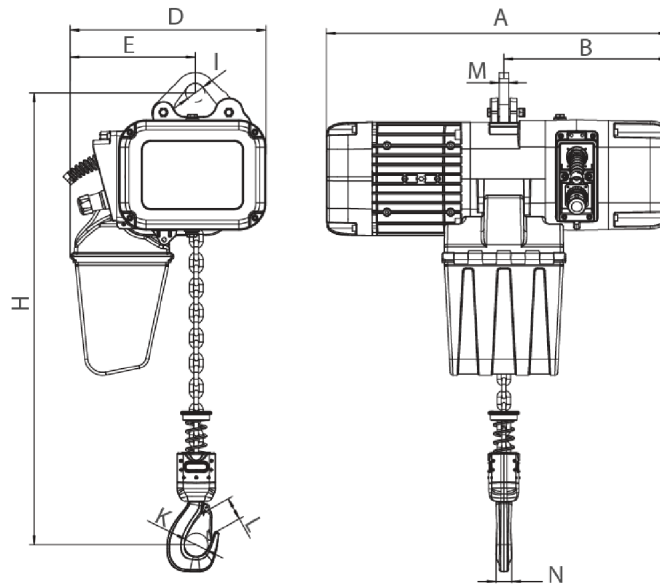

[Size list: mm]

| Rated load (t) | Type | Minimum distance between hooks: H | A | B | D | E | I | M | N | K | L |
|----------------|-----------|-----------------------------------|-----|-----|-----|-----|----|----|----|----|----|
| 1 | PWRXF1-01 | 455 | 590 | 276 | 330 | 210 | 32 | 16 | 25 | 42 | 32 |
| 2 | PWRXF2-01 | 550 | 590 | 276 | 330 | 210 | 38 | 20 | 35 | 52 | 42 |
| 3 | PWRXF3-01 | 560 | 695 | 350 | 420 | 265 | 45 | 20 | 34 | 59 | 48 |
| 5 | PWRXF5-02 | 675 | 695 | 350 | 420 | 307 | 55 | 28 | 44 | 60 | 48 |

Unit Weight & Dimensions

| | |
|--|------------|
| A Total Height | 560 |
| J Hook Opening | 59 |
| W Width | 420 |
| H Minimum Headroom | 645 |
| D Depth | 695 |
| 1st Package Type | Wood Crate |
| Total Weight (w/out cable or Chain) | 130 |

Packaging Weight & Dimensions

| | |
|-------------------------------|-------------------|
| Package 1 Height | 31 in / 78.74 cm |
| Package 1 Net Weight | 184.8 lbs / 84 Kg |
| Package 1 Width | 20 in / 50.8 cm |
| Package 1 Gross Weight | 330 lbs / 150 Kg |
| Package 1 Length | 30 in / 76.2 cm |

Total Unit Weight

184.8 lbs / 84 Kg