



2 ton Electric Chain Hoist Variable Speed 380V 3ø 50~60HZ 20ft G100 Nickel Duty H4/M5

Key features

- Lifting Capacity: 2 tons (4,000 lbs)
- Power Supply: 380V, 3-phase, 50~60Hz
- Speed Control: Variable speed for precise lifting and positioning
- 3 Year Warranty, Customer Support and Service in the USA

Electric Chain Hoist Description

The 2 Ton Electric Chain Hoist with variable speed control is engineered for precision and versatility in industrial lifting applications. Capable of lifting up to 2 tons, this hoist operates on 380V, 3-phase, 50~60Hz power, providing flexibility for various operational needs. The variable speed feature allows for smooth and controlled lifting, making it ideal for tasks requiring accuracy and careful positioning. Built for durability and equipped with essential safety mechanisms, this hoist is perfect for demanding environments.

Technical Specifications

Rated Load Capacity	2 ton	Chain Falls	1
Standard Lifting Height	20 ft / 6 m	Chain Length	20
Speed (f/m) / min	ft @60Hz 0.8~6.8 mt @50Hz	Humidity	20%~90%
Number of Speeds	Variable Speed	Temperature	-4 ~ 104° F / -20 ~ 40° C
Capacity Range	3	Standards Compliance	ASME HST-1 , ASME B30.16 , EN60204-34
Voltage	3 Phase 380V 50Hz	Warranty	3 Year
Total Power Watts	4000	Hoist VFD Power	4kW
Duty Class	H4/M5/2m/Class D	Hoist VFD Brand	HUAYUAN
IEC Motor Protection	IP55	Hoist Motor Power in KW	3
Control	Pendant Control IP66 and Optional Wireless	Hour Meter	Internal Working Hour Meter
Control Voltage	24V	Hoist Motor Insulation Grade	F
Emergency Stop	Yes	IEC Hoist IP Protection	IP55
Transmission / Reducer Type	Spur gearbox	IEC Pendant Control Protection	IP66
Load Chain Type	G100 Nikel	Hoist Motor Brake Type and DC Voltage	DC170V
Load Chain Size	10 mm		

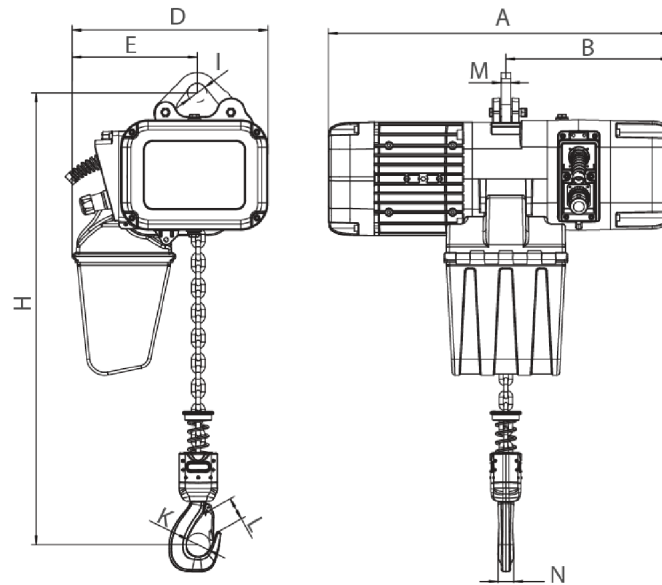

[Size list: mm]

Rated load (t)	Type	Minimum distance between hooks: H	A	B	D	E	I	M	N	K	L
1	PWRXF1-01	455	590	276	330	210	32	16	25	42	32
2	PWRXF2-01	550	590	276	330	210	38	20	35	52	42
3	PWRXF3-01	560	695	350	420	265	45	20	34	59	48
5	PWRXF5-02	675	695	350	420	307	55	28	44	60	48

Unit Weight & Dimensions

H Minimum Headroom	600
J Hook Opening	52
A Total Height	540
Total Weight (w/out cable or Chain)	155
D Depth	695
1st Package Type	Wood Crate
W Width	420

Packaging Weight & Dimensions

Package 1 Net Weight	184.8 lbs / 84 Kg
Package 1 Width	20 in / 50.8 cm
Package 1 Gross Weight	308 lbs / 140 Kg
Package 1 Height	31 in / 78.74 cm
Package 1 Length	30 in / 76.2 cm

Total Unit Weight

184.8 lbs / 84 Kg