



2 ton Electric Chain Hoist Variable Speed 110V 1ø 60HZ 20ft G100 Nickel Duty H4/M5

Key features

- Capacity: Lifts up to 2 tons (approximately 4,000 lbs)
- Power Supply: 110V single-phase, 60Hz for easy compatibility
- Speed Control: Variable speed operation for precise lifting and lowering
- 3 Year Warranty, Customer Support and Service in the USA

Electric Chain Hoist Description

The 2 Ton Electric Chain Hoist is a high-capacity and versatile lifting solution designed for demanding applications. With variable speed control and a 110V single-phase 60Hz power supply, this hoist provides precise handling of heavy loads. Its robust construction ensures safety and reliability, making it ideal for industrial and commercial use.

Technical Specifications

Rated Load Capacity	2 ton	Chain Falls	1
Standard Lifting Height	20 ft / 6 m	Chain Length	20
Speed (f/m) / min	ft @60Hz 0.8~6.8 mt @50Hz	Humidity	20%~90%
Number of Speeds	Variable Speed	Temperature	-4 ~ 104° F / -20 ~ 40° C
Voltage	1 Phase 110~120V 60Hz	Standards Compliance	ASME HST-1 , ASME B30.16 , EN60204-34
Total Power Watts	4000	Warranty	3 Year
Duty Class	H4/M5/2m/Class D	Hoist VFD Power	4kW
IEC Motor Protection	IP55	Hoist VFD Brand	HUAYUAN
Control	Pendant Control IP66 and Industrial Wireless Control	Hoist Motor Power in KW	3
Control Voltage	24V	Hour Meter	Internal Working Hour Meter
Emergency Stop	Yes	Hoist Motor Insulation Grade	F
Transmission / Reducer Type	Spur gearbox	IEC Hoist IP Protection	IP55
Load Chain Type	G100 Nikel	IEC Pendant Control Protection	IP66
Load Chain Size	10 mm	Hoist Motor Brake Type and DC Voltage	DC170V

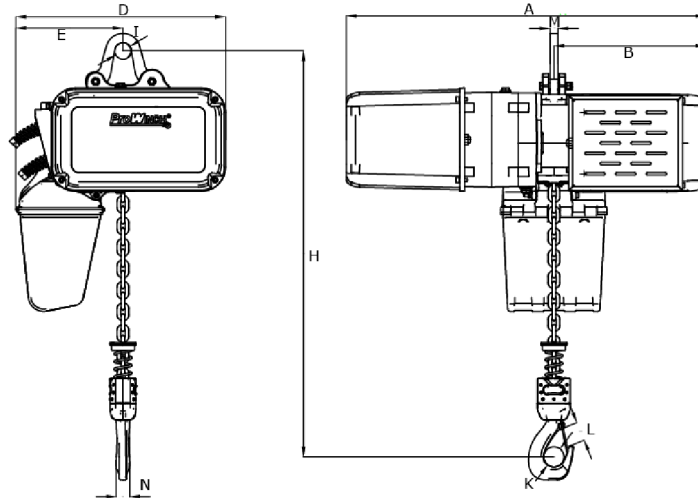

[Size list: mm]

Rated load (t)	Type	Minimum distance between hooks: H	A	B	D	E	I	M	N	K	L
1	PWRXF1-VS-110V	499	704-5	298	410	209	31	24	25	42	32
2-3	PWRXF2-3-VS-110V	540	780	348	463	263	45	20	35	52	42

Unit Weight & Dimensions

H Minimum Headroom	600
J Hook Opening	52
A Total Height	540
Total Weight (w/out cable or Chain)	155
D Depth	695
1st Package Type	Wood Crate
W Width	420

Packaging Weight & Dimensions

Package 1 Net Weight	184.8 lbs / 84 Kg
Package 1 Width	20 in / 50.8 cm
Package 1 Gross Weight	308 lbs / 140 Kg
Package 1 Height	31 in / 78.74 cm
Package 1 Length	30 in / 76.2 cm

Total Unit Weight

184.8 lbs / 84 Kg