



2 ton Electric Chain Hoist 1 Speed 380V 3ø 50HZ 20ft G100 Nickel Duty H4/M5

Key features

- Lifting Capacity: 2 tons (4,000 lbs)
- Power Supply: 380V, 3-phase, 50Hz
- Speed: Single speed operation for dependable lifting
- 3 Year Warranty, Customer Support and Service in the USA

Electric Chain Hoist Description

The 2 Ton Electric Chain Hoist is designed for reliable lifting in industrial applications, offering a robust solution for heavy-duty tasks. With a lifting capacity of 2 tons, this hoist operates at 380V, 3-phase, 50Hz, ensuring efficient performance for various settings. Featuring a single speed for consistent operation, it is perfect for lifting heavy loads safely and efficiently. Built for durability, this hoist is ideal for demanding work environments.

Our Dedication to Excellence:

At Prowinch, our unwavering commitment to delivering the best price-performance ratio is evident in every Electric Chain Hoist we produce. We subject each unit to meticulous testing and continuously enhance key components, considering factors that influence lifespan. This commitment ensures that we consistently provide a superior product at an optimal price point.

Enhanced Components:

Internally, each component has undergone substantial upgrades to meet the highest quality standards. Key electronic parts are carefully sourced from reputable brands, while locally manufactured lubricants are employed to fortify the durability of gears and reducers. The final assembly and testing processes take place in the US, guaranteeing that every unit surpasses corresponding standards.

Single Speed Efficiency:

Our Single Speed Electric Chain Hoist is designed for straightforward yet efficient lifting operations. Perfect for applications where a consistent lifting speed is paramount, this hoist offers reliability and ease of use.

Duty Classification:

Choosing the right unit is pivotal, and our M5-rated H4 hoists stand out for their excellence in high-volume handling. Tailored for environments like steel warehouses, machine shops, fabricating plants, and mills, these hoists boast a 50% maximum operational time per hour for uniformly distributed work periods. They can efficiently handle up to 300 starts per hour. In scenarios of infrequent work periods, the hoist can operate for 30 minutes from a cold start with up to 300 starts per hour. Operational time ratings adhere to a 65% load factor, following ASME HST-1-2012 guidelines.

Control System:

The Single Speed Electric Chain Hoist comes with a standard pendant control, designed with a length 4 feet less than the lifting height, ensuring easy operation from ground level. For added convenience, an optional wireless control is available.

Advanced Braking System:

Our hoists feature an electromagnetic brake system, rigorously tested at 125% of the hoist capacity. This system is intelligently designed to engage automatically upon any loss of power, ensuring not only enhanced safety but also precise control over the operation of the hoist.

Technical Specifications

Rated Load Capacity	2 ton	Chain Falls	1
Standard Lifting Height	20 ft / 6 m	Chain Length	20
Speed (f/m) / min	26.77 ft @60Hz 6.80 mt @50Hz	Humidity	20%~90%
Number of Speeds	1 Speed	Temperature	-4 ~ 104° F / -20 ~ 40° C
Capacity Range	3	Standards Compliance	ASME HST-1 , ASME B30.16 , EN60204-34
Voltage	3 Phase 380V 50Hz	Warranty	3 Year
Total Power Watts	3000	Hoist Motor Power in KW	3
Duty Class	H4/M5/2m/Class D	Hour Meter	Internal Working Hour Meter
IEC Motor Protection	IP55	Hoist Motor Insulation Grade	F
Control	Pendant Control IP66 and Optional Wireless	Hoist Contactor Coil Voltage	24 V
Control Voltage	24V	Hoist Contactors Amps	18A
Emergency Stop	Yes	Hoist Contactor Brand	Schneider
Transmission / Reducer Type	Spur gearbox	IEC Hoist IP Protection	IP55
Load Chain Type	G100 Nickel	IEC Pendant Control Protection	IP66
Load Chain Size	10 mm	Hoist Motor Brake Type and DC Voltage	DC170V

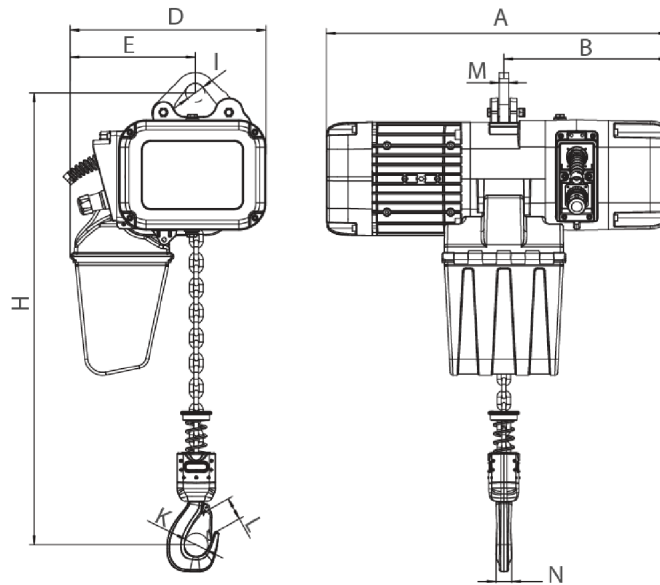

[Size list: mm]

Rated load (t)	Type	Minimum distance between hooks: H	A	B	D	E	I	M	N	K	L
1	PWRXF1-01	455	590	276	330	210	32	16	25	42	32
2	PWRXF2-01	550	590	276	330	210	38	20	35	52	42
3	PWRXF3-01	560	695	350	420	265	45	20	34	59	48
5	PWRXF5-02	675	695	350	420	307	55	28	44	60	48

Unit Weight & Dimensions

H Minimum Headroom	600
J Hook Opening	52
A Total Height	540
Total Weight (w/out cable or Chain)	170
D Depth	695
1st Package Type	Wood Crate
W Width	420

Packaging Weight & Dimensions

Package 1 Net Weight	184.8 lbs / 84 Kg
Package 1 Width	20 in / 50.8 cm
Package 1 Gross Weight	209 lbs / 95 Kg
Package 1 Height	31 in / 78.74 cm
Package 1 Length	30 in / 76.2 cm

Total Unit Weight

184.8 lbs / 84 Kg