



2 ton Electric Chain Hoist 1 Speed 208~240V / 440~480V 3ø 60HZ 20ft G100 Nickel Duty H4/M5

Key features

- Lifting Capacity: 2 tons (4,000 lbs)
- Power Supply Options: 208~240V / 440~480V, 3-phase, 60Hz
- Speed: Single speed operation for consistent lifting
- 3 Year Warranty, Customer Support and Service in the USA

Electric Chain Hoist Description

The 2 Ton Electric Chain Hoist is a powerful lifting solution designed for industrial applications. With a lifting capacity of 2 tons, this hoist operates on dual voltage options of 208~240V / 440~480V, 3-phase, 60Hz, ensuring versatility for different setups. Featuring a single speed for reliable operation, it is perfect for various heavy lifting tasks. Built for durability and equipped with safety features, this hoist is ideal for demanding environments.

Our Dedication to Excellence:

At Prowinch, our unwavering commitment to delivering the best price-performance ratio is evident in every Electric Chain Hoist we produce. We subject each unit to meticulous testing and continuously enhance key components, considering factors that influence lifespan. This commitment ensures that we consistently provide a superior product at an optimal price point.

Enhanced Components:

Internally, each component has undergone substantial upgrades to meet the highest quality standards. Key electronic parts are carefully sourced from reputable brands, while locally manufactured lubricants are employed to fortify the durability of gears and reducers. The final assembly and testing processes take place in the US, guaranteeing that every unit surpasses corresponding standards.

Single Speed Efficiency:

Our Single Speed Electric Chain Hoist is designed for straightforward yet efficient lifting operations. Perfect for applications where a consistent lifting speed is paramount, this hoist offers reliability and ease of use.

Duty Classification:

Choosing the right unit is pivotal, and our M5-rated H4 hoists stand out for their excellence in high-volume handling. Tailored for environments like steel warehouses, machine shops, fabricating plants, and mills, these hoists boast a 50% maximum operational time per hour for uniformly distributed work periods. They can efficiently handle up to 300 starts per hour. In scenarios of infrequent work periods, the hoist can operate for 30 minutes from a cold start with up to 300 starts per hour. Operational time ratings adhere to a 65% load factor, following ASME HST-1-2012 guidelines.

Control System:

The Single Speed Electric Chain Hoist comes with a standard pendant control, designed with a length 4 feet less than the lifting height, ensuring easy operation from ground level. For added convenience, an optional wireless control is available.

Advanced Braking System:

Our hoists feature an electromagnetic brake system, rigorously tested at 125% of the hoist capacity. This system is intelligently designed to engage automatically upon any loss of power, ensuring not only enhanced safety but also precise control over the operation of the hoist.

Technical Specifications

| | | | |
|------------------------------------|---|--|--|
| Rated Load Capacity | 2 ton | Chain Length | 20 |
| Standard Lifting Height | 20 ft / 6 m | Humidity | 20%~90% |
| Speed (f/m) / min | 26.77 ft @60Hz 6.80 mt @50Hz | Temperature | -4 ~ 104° F / -20 ~ 40° C |
| Number of Speeds | 1 Speed | Standards Compliance | ASME HST-1 , ASME B30.16 , EN60204-34 |
| Voltage | 3 Phase 208~240/440~480V 50/60Hz | Warranty | 3 Year |
| Total Power Watts | 3000 | Hoist UL Components | UL Listed Contactors |
| Duty Class | H4/M5/2m/Class D | Hoist Motor Power in KW | 3 |
| IEC Motor Protection | IP55 | Hour Meter | Internal Working Hour Meter |
| Control | Pendant Control IP66 and Optional Wireless | Hoist Motor Insulation Grade | F |
| Control Voltage | 24V | Hoist Contactor Coil Voltage | 24 V |
| Emergency Stop | Yes | Hoist Contactors Amps | 25A |
| Transmission / Reducer Type | Spur gearbox | Hoist Contactor Brand | Schneider |
| Load Chain Type | G100 Nikel | IEC Hoist IP Protection | IP55 |
| Load Chain Size | 10 mm | IEC Pendant Control Protection | IP66 |
| Chain Falls | 1 | Hoist Motor Brake Type and DC Voltage | DC99V/DC207V |

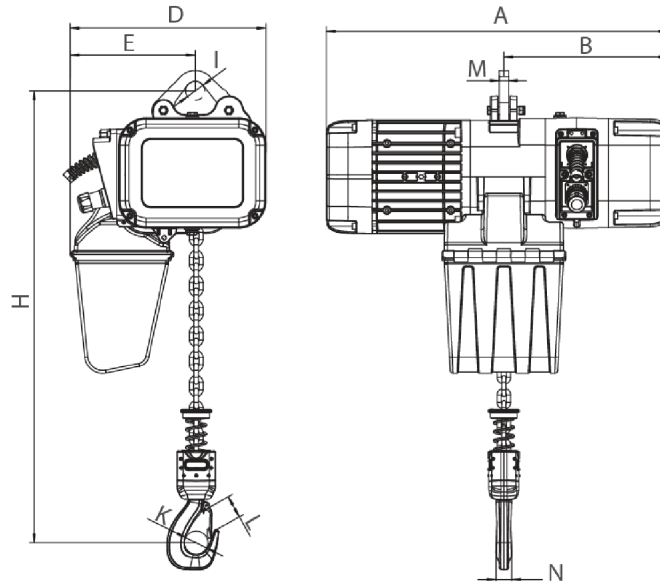

[Size list: mm]

| Rated load (t) | Type | Minimum distance between hooks: H | A | B | D | E | I | M | N | K | L |
|----------------|-----------|-----------------------------------|-----|-----|-----|-----|----|----|----|----|----|
| 1 | PWRXF1-01 | 455 | 590 | 276 | 330 | 210 | 32 | 16 | 25 | 42 | 32 |
| 2 | PWRXF2-01 | 550 | 590 | 276 | 330 | 210 | 38 | 20 | 35 | 52 | 42 |
| 3 | PWRXF3-01 | 560 | 695 | 350 | 420 | 265 | 45 | 20 | 34 | 59 | 48 |
| 5 | PWRXF5-02 | 675 | 695 | 350 | 420 | 307 | 55 | 28 | 44 | 60 | 48 |

Unit Weight & Dimensions

| | |
|--|------------|
| H Minimum Headroom | 600 |
| J Hook Opening | 52 |
| A Total Height | 540 |
| Total Weight (w/out cable or Chain) | 155 |
| D Depth | 695 |
| 1st Package Type | Wood Crate |
| W Width | 420 |

Packaging Weight & Dimensions

| | |
|-------------------------------|-------------------|
| Package 1 Net Weight | 184.8 lbs / 84 Kg |
| Package 1 Width | 20 in / 50.8 cm |
| Package 1 Gross Weight | 209 lbs / 95 Kg |
| Package 1 Height | 31 in / 78.74 cm |
| Package 1 Length | 30 in / 76.2 cm |

Total Unit Weight

184.8 lbs / 84 Kg