



1 ton Electric Chain Hoist Variable Speed 380V 3ø 50~60HZ 20ft G100 Nickel Duty H4/M5

Key features

- Heavy Duty H4/M5 US and EC Standards ASME HST-1 , ASME B30.16 , EN14492-2 , EN60204-32
- Patented Overload Motor Slip Protection with Heavy Duty Electromagnetic Disk Brake
- Variable Speed Inverter with Potentiometer for Precise Control, Dual System Limit Switches, Emergency Stop
- Super Heavy Duty G100 Nickel Chain, 25% Stronger than G80. Standard ASTM A973
- 3 Year Warranty, Customer Support and Service in the USA

1 ton Electric Chain Hoist Variable Speed 380V 3ø 50~60HZ

Technical Specifications

Rated Load Capacity	1 ton	Total Power Watts	4000
Capacity Range	2	Power Cord Length and Phase Order	3 ft / Red L1, White L2 and Black L3, Green ground
Voltage	3 Phase 380V 50Hz	Recommended Hoist Protection Circuit Breaker AMPs and Type	Type D 15A
Standard Lifting Height	20 ft / 6 m	Optional Load Chain Brand & Country of Origin	FEC Japan
Speed (f/m) / min	ft @60Hz 0.8~7 mt @50Hz	Load Chain Type	G100 Nikel
Number of Speeds	Variable Speed	Load Chain Size	7.1 mm
Hoist VFD Power	4kW	Chain Falls	1
Hoist VFD Brand	HUAYUAN	Chain Length	20
VFD Model	Z230	Load Chain weight per foot [lbs]	0.74
Brake Resistor Kw	0.6Kw	Humidity	20%~90%
Duty Class	H4/M5/2m/Class D	Temperature	-4 ~ 104° F / -20 ~ 40° C
IEC Hoist IP Protection	IP55	Transmission / Reducer Type	Spur gearbox
IEC Motor Protection	IP55	Reducer Lubrication Type	Oil
Pendant Control Yes No	Yes	Paint Specifications	Electrostatic Sprayed Plastic (ESP) Epoxy resins, Polyester Resins, Barium, Pigments
IEC Pendant Control Protection	IP66	Standards Compliance	ASME HST-1 , ASME B30.16 , EN60204-33
Pendant Control Emergency Stop	Yes	Standards Certified	CE
Pendant Control total Length	17 ft	Overload Protection	Overload Motor Clutch
Hoist Motor Power in KW	1.5	Hour Meter	Internal Working Hour Meter
Hoist Motor Brake Type and DC Voltage	DC170V	Brake SKU	PWRX-1-PN.60.61
Hoist Motor Insulation Grade	F	Brake rectifiers-half-wave	PWRX-BKTF-HW

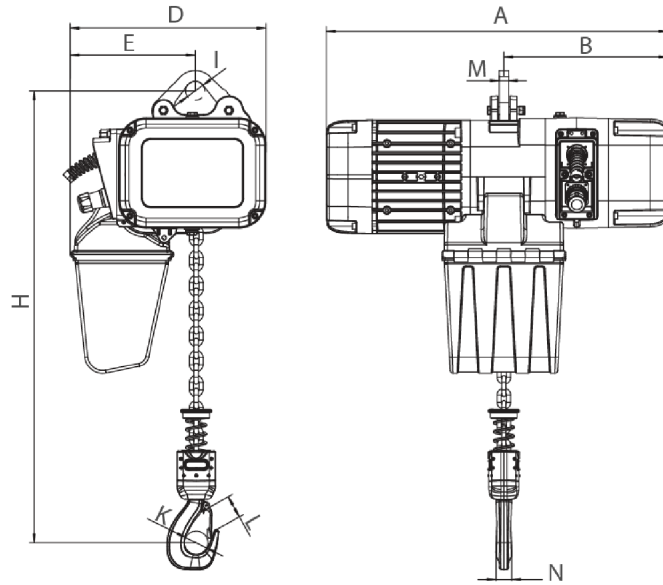

[Size list: mm]

Rated load (t)	Type	Minimum distance between hooks: H	A	B	D	E	I	M	N	K	L
1	PWRXF1-01	455	590	276	330	210	32	16	25	42	32
2	PWRXF2-01	550	590	276	330	210	38	20	35	52	42
3	PWRXF3-01	560	695	350	420	265	45	20	34	59	48
5	PWRXF5-02	675	695	350	420	307	55	28	44	60	48

Unit Weight & Dimensions

A Total Height	455
J Hook Opening	42
W Width	330
H Minimum Headroom	516
D Depth	590
1st Package Type	Wood Crate
Total Weight (w/out cable or Chain)	86

Packaging Weight & Dimensions

Package 1 Height	26 in / 66.04 cm
Package 1 Net Weight	101.64 lbs / 46 Kg
Package 1 Width	16 in / 40.64 cm
Package 1 Gross Weight	209 lbs / 95 Kg
Package 1 Length	26 in / 66.04 cm

Total Unit Weight

101.64 lbs / 47 Kg