



1 ton Electric Chain Hoist Variable Speed 220V 1ø 50~60HZ

1 ton Electric Chain Hoist Variable Speed 220V 1ø 50~60HZ

Technical Specifications

Rated Load Capacity	1 ton	Hoist Motor Brake Type and DC Voltage	DC170V
Capacity Range	3	Hoist Motor Insulation Grade	F
Voltage	1 Phase 220~240V 50/60Hz	Total Power Watts	4000
Standard Lifting Height	20 ft / 6 m	Power Cord Length and Phase Order	3 ft / Black L1, White, Green ground
Speed (f/m) / min	ft @60Hz 0.8~7 mt @50Hz	Recommended Hoist Protection Circuit Breaker AMPs and Type	Type D 15A
Number of Speeds	Variable Speed	Optional Load Chain Brand & Country of Origin	FEC Japan
Hoist VFD Power	4kW	Load Chain Type	G100 Nikel
Hoist VFD Brand	HUAYUAN	Load Chain Size	7.1 mm
VFD Model	Z230	Chain Falls	1
Brake Resistor Kw	0.6Kw	Chain Length	20
Duty Class	H4/M5/2m/Class D	Load Chain weight per foot [lbs]	0.74
IEC Hoist IP Protection	IP55	Humidity	20%~90%
IEC Motor Protection	IP55	Temperature	-4 ~ 104° F / -20 ~ 40° C
Pendant Control Yes No	Yes	Transmission / Reducer Type	Spur gearbox
IEC Pendant Control Protection	IP66	Reducer Lubrication Type	Oil
Pendant Control Emergency Stop	Yes	Paint Specifications	Electrostatic Sprayed Plastic (ESP) Epoxy resins, Polyester Resins, Barium, Pigments
Pendant Control total Length	17 ft	Standards Compliance	ASME HST-1 , ASME B30.16 , EN60204-33
Hoist Motor Power in KW	1.5	Standards Certified	CE

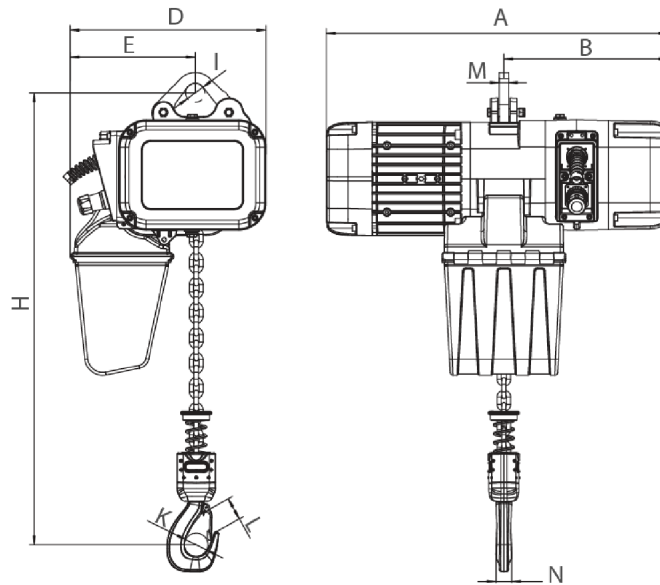

[Size list: mm]

Rated load (t)	Type	Minimum distance between hooks: H	A	B	D	E	I	M	N	K	L
1	PWRXF1-01	455	590	276	330	210	32	16	25	42	32
2	PWRXF2-01	550	590	276	330	210	38	20	35	52	42
3	PWRXF3-01	560	695	350	420	265	45	20	34	59	48
5	PWRXF5-02	675	695	350	420	307	55	28	44	60	48

Unit Weight & Dimensions

A Total Height	455
J Hook Opening	42
W Width	330
H Minimum Headroom	516
D Depth	590
1st Package Type	Wood Crate
Total Weight (w/out cable or Chain)	86

Packaging Weight & Dimensions

Package 1 Height	26 in / 66.04 cm
Package 1 Net Weight	101.64 lbs / 46 Kg
Package 1 Width	16 in / 40.64 cm
Package 1 Gross Weight	209 lbs / 95 Kg
Package 1 Length	26 in / 66.04 cm

Total Unit Weight

101.64 lbs / 47 Kg