



1 ton Electric Chain Hoist Variable Speed 440~480V 3ø 50~60HZ

Key features

- Heavy Duty H4/M5 US and EC Standards ASME HST-1 , ASME B30.16 , EN14492-2 , EN60204-32
- Patented Overload Motor Slip Protection with Heavy Duty Electromagnetic Disk Brake
- Variable Speed Inverter with Potentiometer for Precise Control, Dual System Limit Switches, Emergency Stop
- Super Heavy Duty G100 Nickel Chain, 25% Stronger than G80. Standard ASTM A973
- 3 Year Warranty, Customer Support and Service in the USA

1 ton Electric Chain Hoist Variable Speed 440~480V 3ø 50~60HZ

Our Dedication to Excellence:

At Prowinch, our unwavering commitment to delivering the best price-performance ratio is evident in every Electric Chain Hoist we produce. We subject each unit to meticulous testing and continuously enhance key components, considering factors that influence lifespan. This commitment ensures that we consistently provide a superior product at an optimal price point.

Enhanced Components:

Internally, each component has undergone substantial upgrades to meet the highest quality standards. Key electronic parts are carefully sourced from reputable brands, while locally manufactured lubricants are employed to fortify the durability of gears and reducers. The final assembly and testing processes take place in the US, guaranteeing that every unit surpasses corresponding standards.

Variable Speed Innovation:

Designed for unparalleled control, our Variable Speed Electric Chain Hoist offers a dynamic lifting experience. Ideal for applications requiring precise load positioning, this hoist allows you to adjust lifting speeds according to the specific needs of your project.

Duty Classification:

Choosing the right unit is pivotal, and our M5-rated H4 hoists stand out for their excellence in high-volume handling. Tailored for environments like steel warehouses, machine shops, fabricating plants, and mills, these hoists boast a 50% maximum operational time per hour for uniformly distributed work periods. They can efficiently handle up to 300 starts per hour. In scenarios of infrequent work periods, the hoist can operate for 30 minutes from a cold start with up to 300 starts per hour. Operational time ratings adhere to a 65% load factor, following ASME HST-1-2012 guidelines.

Control System:

The Variable Speed Electric Chain Hoist is equipped with an advanced control system, allowing for precise speed adjustments tailored to your lifting requirements. The standard pendant control, designed with a length 4 feet less than the lifting height, ensures easy operation from ground level. For added convenience, an optional wireless control is available.

Advanced Braking System:

Our hoists feature an electromagnetic brake system, rigorously tested at 125% of the hoist capacity. This system is intelligently designed to engage automatically upon any loss of power, ensuring not only enhanced safety but also precise control over the operation of the hoist.

Technical Specifications

Rated Load Capacity	1 ton	Total Power Watts	4000
Capacity Range	3	Power Cord Length and Phase Order	3 ft / Black L1 , Red L2 and Blue L3 Green ground
Voltage	3 Phase 440~480V 60Hz	Recommended Hoist Protection Circuit Breaker AMPs and Type	Type D 15A
Standard Lifting Height	20 ft / 6 m	Optional Load Chain Brand & Country of Origin	FEC Japan
Speed (f/m) / min	3.1~27.5 ft @60Hz mt @50Hz	Load Chain Type	G100 Nikel
Number of Speeds	Variable Speed	Load Chain Size	7.1 mm
Hoist VFD Power	4kW	Chain Falls	1
Hoist VFD Brand	HUAYUAN	Chain Length	20
VFD Model	Z230	Load Chain weight per foot [lbs]	0.74
Brake Resistor Kw	0.6Kw	Humidity	20%~90%
Duty Class	H4/M5/2m/Class D	Temperature	-4 ~ 104° F / -20 ~ 40° C
IEC Hoist IP Protection	IP55	Transmission / Reducer Type	Spur gearbox
IEC Motor Protection	IP55	Reducer Lubrication Type	Oil
Pendant Control Yes No	Yes	Paint Specifications	Electrostatic Sprayed Plastic (ESP) Epoxy resins, Polyester Resins, Barium, Pigments
IEC Pendant Control Protection	IP66	Standards Compliance	ASME HST-1 , ASME B30.16 , EN60204-33
Pendant Control Emergency Stop	Yes	Standards Certified	CE
Pendant Control total Length	17 ft	Overload Protection	Overload Motor Clutch
Hoist Motor Power in KW	1.5	Hour Meter	Internal Working Hour Meter
Hoist Motor Brake Type and DC Voltage	DC207V	Brake SKU	PWRX-1-PN.60.61
Hoist Motor Insulation Grade	F	Brake rectifiers-half-wave	PWRX-BKTF-HW

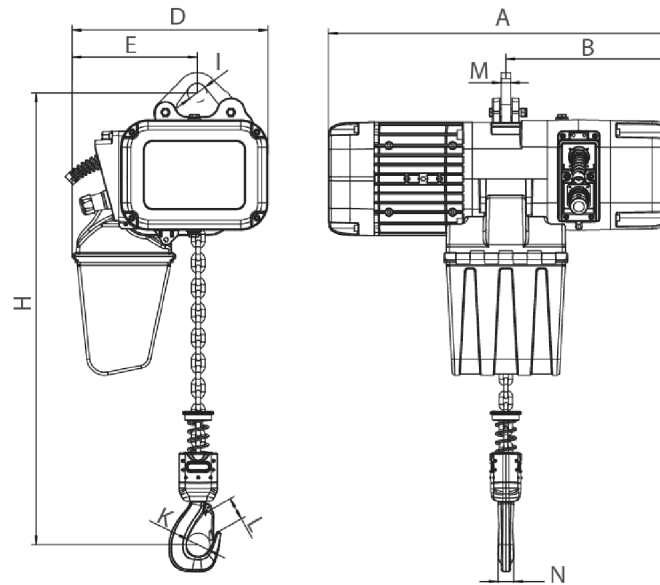

[Size list: mm]

Rated load (t)	Type	Minimum distance between hooks: H	A	B	D	E	I	M	N	K	L
1	PWRXF1-01	455	590	276	330	210	32	16	25	42	32
2	PWRXF2-01	550	590	276	330	210	38	20	35	52	42
3	PWRXF3-01	560	695	350	420	265	45	20	34	59	48
5	PWRXF5-02	675	695	350	420	307	55	28	44	60	48

Unit Weight & Dimensions

A Total Height	455
J Hook Opening	42
W Width	330
H Minimum Headroom	516
D Depth	590
1st Package Type	Wood Crate
Total Weight (w/out cable or Chain)	86

Packaging Weight & Dimensions

Package 1 Height	26 in / 66.04 cm
Package 1 Net Weight	101.64 lbs / 46 Kg
Package 1 Width	16 in / 40.64 cm
Package 1 Gross Weight	209 lbs / 95 Kg
Package 1 Length	26 in / 66.04 cm

Total Unit Weight

101.64 lbs / 47 Kg