



1 ton Electric Chain Hoist 1 Speed 380V 3ø 50HZ 20ft G100 Nickel Duty H4/M5

Key features

- Lifting Capacity: 1 ton (2,000 lbs)
- Power Supply: 380V, 3-phase, 50Hz
- Speed: Single speed operation for dependable lifting
- 3 Year Warranty, Customer Support and Service in the USA

Electric Chain Hoist Description

The 1 Ton Electric Chain Hoist is engineered for heavy-duty lifting in industrial environments. With a capacity of 1 ton, this hoist operates at 380V, 3-phase, 50Hz, providing robust performance for various applications. Designed for single speed operation, it ensures consistent and reliable lifting, making it ideal for demanding tasks. Its durable construction and safety features make it a dependable choice for any industrial setting.

Our Dedication to Excellence:

At Prowinch, our unwavering commitment to delivering the best price-performance ratio is evident in every Electric Chain Hoist we produce. We subject each unit to meticulous testing and continuously enhance key components, considering factors that influence lifespan. This commitment ensures that we consistently provide a superior product at an optimal price point.

Enhanced Components:

Internally, each component has undergone substantial upgrades to meet the highest quality standards. Key electronic parts are carefully sourced from reputable brands, while locally manufactured lubricants are employed to fortify the durability of gears and reducers. The final assembly and testing processes take place in the US, guaranteeing that every unit surpasses corresponding standards.

Single Speed Efficiency:

Our Single Speed Electric Chain Hoist is designed for straightforward yet efficient lifting operations. Perfect for applications where a consistent lifting speed is paramount, this hoist offers reliability and ease of use.

Duty Classification:

Choosing the right unit is pivotal, and our M5-rated H4 hoists stand out for their excellence in high-volume handling. Tailored for environments like steel warehouses, machine shops, fabricating plants, and mills, these hoists boast a 50% maximum operational time per hour for uniformly distributed work periods. They can efficiently handle up to 300 starts per hour. In scenarios of infrequent work periods, the hoist can operate for 30 minutes from a cold start with up to 300 starts per hour. Operational time ratings adhere to a 65% load factor, following ASME HST-1-2012 guidelines.

Control System:

The Single Speed Electric Chain Hoist comes with a standard pendant control, designed with a length 4 feet less than the lifting height, ensuring easy operation from ground level. For added convenience, an optional wireless control is available.

Advanced Braking System:

Our hoists feature an electromagnetic brake system, rigorously tested at 125% of the hoist capacity. This system is intelligently designed to engage automatically upon any loss of power, ensuring not only enhanced safety but also precise control over the operation of the hoist.

Technical Specifications

Rated Load Capacity	1 ton	Chain Falls	1
Standard Lifting Height	20 ft / 6 m	Chain Length	20
Speed (f/m) / min	25.59 ft @60Hz 6.50 mt @50Hz	Humidity	20%~90%
Number of Speeds	1 Speed	Temperature	-4 ~ 104° F / -20 ~ 40° C
Capacity Range	2	Standards Compliance	ASME HST-1 , ASME B30.16 , EN60204-33
Voltage	3 Phase 380V 50Hz	Warranty	3 Year
Total Power Watts	1500	Hoist Motor Power in KW	1.5
Duty Class	H4/M5/2m/Class D	Hour Meter	Internal Working Hour Meter
IEC Motor Protection	IP55	Hoist Motor Insulation Grade	F
Control	Pendant Control IP66 and Optional Wireless	Hoist Contactor Coil Voltage	24 V
Control Voltage	24V	Hoist Contactors Amps	18A
Emergency Stop	Yes	Hoist Contactor Brand	Schneider
Transmission / Reducer Type	Spur gearbox	IEC Hoist IP Protection	IP55
Load Chain Type	G100 Nikel	IEC Pendant Control Protection	IP66
Load Chain Size	7.1 mm	Hoist Motor Brake Type and DC Voltage	DC170V

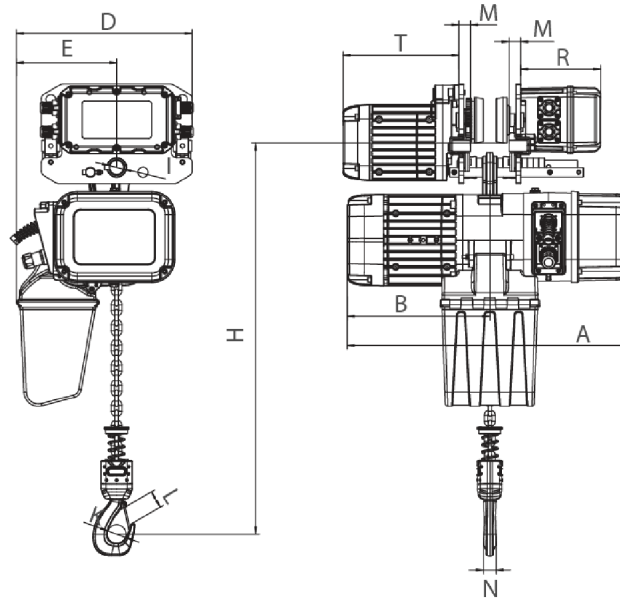

Rated load (t)	Type	Dimension (mm)												
		Minimum distance from the bottom of the track to the bottom hook: H	A	L	B	D	E	I	M	N	K	L	T	R
1	PWRXT1-01	473	440	3500-5500	285	210	20	105	140					
2	PWRXT2-01	516	590		276	368	210	31	24	25	42	32	242	167
3	PWRXT3-01	600	681		350	422	264	36	28	35	52	42	242	167
5	PWRXT5-02	645	681		350	478	307	43	30	34	59	48	242	167

Unit Weight & Dimensions

H Minimum Headroom	516
J Hook Opening	42

Packaging Weight & Dimensions

Package 1 Net Weight	101.64 lbs / 46 Kg
Package 1 Width	16 in / 40.64 cm

A Total Height	455	Package 1 Gross Weight	121 lbs / 55 Kg
Total Weight (w/out cable or Chain)	90	Package 1 Height	26 in / 66.04 cm
D Depth	590	Package 1 Length	26 in / 66.04 cm
1st Package Type	Wood Crate		
W Width	330		
Total Unit Weight	101.64 lbs / 47 Kg		