



1/2 ton Electric Chain Hoist Variable Speed 380V 3ø 50~60HZ 13ft G100 Nickel Duty H4/M5

Key features

- Lifting Capacity: 1/2 ton (1,000 lbs)
- Power Supply: 380V, 3-phase, 50~60Hz
- Speed Control: Variable speed for precise lifting and positioning
- 3 Year Warranty, Customer Support and Service in the USA

Electric Chain Hoist Description

The 1/2 Ton Electric Chain Hoist with variable speed control is designed for precision lifting in industrial environments. Capable of handling loads up to 1/2 ton, this hoist operates on 380V, 3-phase, 50~60Hz power, offering versatility for various applications. The variable speed feature allows for smooth adjustments, ensuring accurate positioning during lifting tasks. Built for durability and equipped with safety mechanisms, this hoist is ideal for demanding operational settings.

Technical Specifications

Rated Load Capacity	1/2 ton	Chain Falls	1
Standard Lifting Height	13 ft / 4 m	Chain Length	13
Speed (f/m) / min	ft @60Hz 1~8 mt @50Hz	Humidity	20%~90%
Number of Speeds	Variable Speed	Temperature	-4 ~ 104° F / -20 ~ 40° C
Voltage	3 Phase 380V 50Hz	Standards Compliance	ASME HST-1 , ASME B30.16 , EN60204-37
Total Power Watts	1500	Warranty	3 Year
Duty Class	H4/M5/2m/Class D	Hoist VFD Power	1.5kW
IEC Motor Protection	IP55	Hoist VFD Brand	HUAYUAN
Control	Pendant Control IP66 and Optional Wireless	Hoist Motor Power in KW	0.75
Control Voltage	24V	Hour Meter	Internal Working Hour Meter
Emergency Stop	Yes	Hoist Motor Insulation Grade	F
Transmission / Reducer Type	Spur gearbox	IEC Hoist IP Protection	IP55
Load Chain Type	G100 Nickel	IEC Pendant Control Protection	IP66
Load Chain Size	6.3mm	Hoist Motor Brake Type and DC Voltage	DC170V

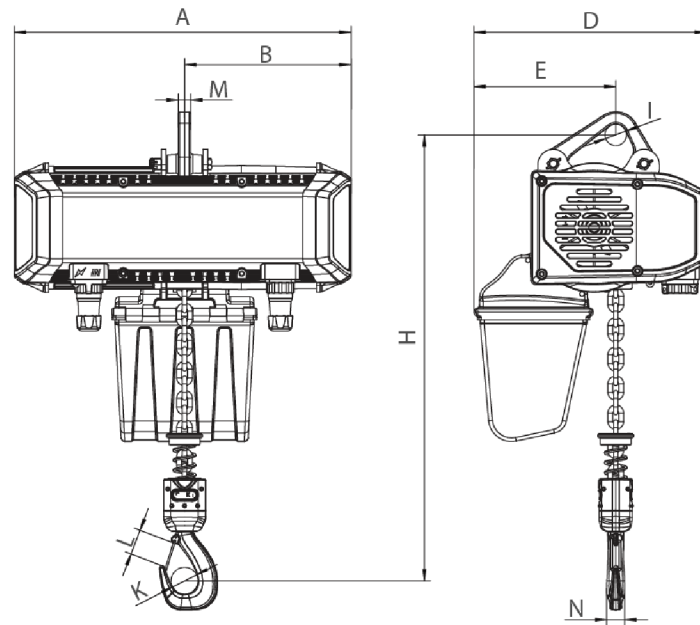

[Size list: mm]

Rated load (t)	Type	Minimum distance between hooks: H	A	B	D	E	I	M	N	K	L
0-25-0-5	PWRXF0-25-0-5-VS	399	447	217	337	179	31	16	20	35	31

Unit Weight & Dimensions

H Minimum Headroom	396
J Hook Opening	35
A Total Height	396
Total Weight (w/out cable or Chain)	64
D Depth	440
1st Package Type	Wood Crate
W Width	305
Total Unit Weight	72.16 lbs / 33 Kg

Packaging Weight & Dimensions

Package 1 Net Weight	72.16 lbs / 33 Kg
Package 1 Width	15 in / 38.1 cm
Package 1 Gross Weight	85.8 lbs / 39 Kg
Package 1 Height	20 in / 50.8 cm
Package 1 Length	20 in / 50.8 cm