



## **1/4 ton Electric Chain Hoist Variable Speed 380V 3ø 50~60HZ 13ft G100 Nickel Duty H4/M5**

### **Key features**

- Lifting Capacity: 1/4 ton (500 lbs)
- Power Supply: 380V, 3-phase, 50~60Hz
- Safety Features: Overload protection and emergency stop for enhanced safety
- 3 Year Warranty, Customer Support and Service in the USA

### **Electric Chain Hoist Description**

The 1/4 Ton Electric Chain Hoist with variable speed control is designed for efficient and precise lifting in various industrial settings. Capable of handling loads up to 1/4 ton, this hoist operates on 380V, 3-phase, 50~60Hz power, providing versatility for different applications. Its variable speed feature allows users to adjust the lifting speed for optimal control, making it ideal for tasks requiring precision. Built for durability and safety, this hoist is a reliable choice for heavy-duty operations.

## Technical Specifications

<b>Rated Load Capacity</b>	1/4 ton	<b>Chain Falls</b>	1
<b>Standard Lifting Height</b>	13 ft / 4 m	<b>Chain Length</b>	13
<b>Speed (f/m) / min</b>	ft @60Hz 1.5~9.6 mt @50Hz	<b>Humidity</b>	20%~90%
<b>Number of Speeds</b>	Variable Speed	<b>Temperature</b>	-4 ~ 104° F / -20 ~ 40° C
<b>Capacity Range</b>	13	<b>Standards Compliance</b>	ASME HST-1 , ASME B30.16 , EN60204-36
<b>Voltage</b>	3 Phase 380V 50Hz	<b>Warranty</b>	3 Year
<b>Total Power Watts</b>	1500	<b>Hoist VFD Power</b>	1.5kW
<b>Duty Class</b>	H4/M5/2m/Class D	<b>Hoist VFD Brand</b>	HUAYUAN
<b>IEC Motor Protection</b>	IP55	<b>Hoist Motor Power in KW</b>	0.5
<b>Control</b>	Pendant Control IP66 and Optional Wireless	<b>Hour Meter</b>	Internal Working Hour Meter
<b>Control Voltage</b>	24V	<b>Hoist Motor Insulation Grade</b>	F
<b>Emergency Stop</b>	Yes	<b>IEC Hoist IP Protection</b>	IP55
<b>Transmission / Reducer Type</b>	Spur gearbox	<b>IEC Pendant Control Protection</b>	IP66
<b>Load Chain Type</b>	G100 Nikel	<b>Hoist Motor Brake Type and DC Voltage</b>	DC170V
<b>Load Chain Size</b>	5mm		

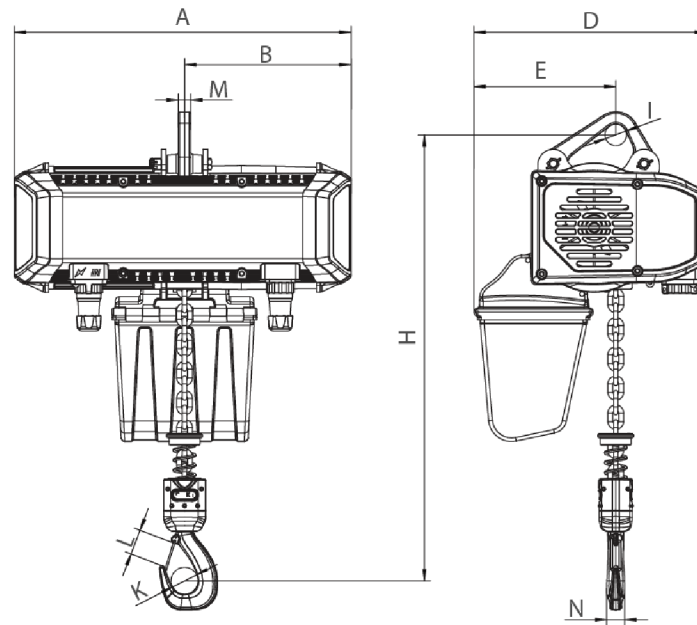

[Size list: mm]

Rated load (t)	Type	Minimum distance between hooks: H	A	B	D	E	I	M	N	K	L
0-25-0-5	PWRXF0-25-0-5-VS	399	447	217	337	179	31	16	20	35	31

## Unit Weight & Dimensions

H Minimum Headroom	385
J Hook Opening	35
A Total Height	385
Total Weight (w/out cable or Chain)	67
D Depth	440
1st Package Type	Wood Crate
W Width	305
Total Unit Weight	72.16 lbs / 33 Kg

## Packaging Weight & Dimensions

Package 1 Net Weight	72.16 lbs / 33 Kg
Package 1 Width	15 in / 38.1 cm
Package 1 Gross Weight	85.8 lbs / 39 Kg
Package 1 Height	20 in / 50.8 cm
Package 1 Length	20 in / 50.8 cm