



## **1/4 ton Electric Chain Hoist Variable Speed 220V 1ø 50~60HZ**

1/4 ton Electric Chain Hoist Variable Speed 220V 1ø 50~60HZ

## Technical Specifications

<b>Rated Load Capacity</b>	1/4 ton	<b>Hoist Motor Brake Type and DC Voltage</b>	DC170V
<b>Capacity Range</b>	1	<b>Hoist Motor Insulation Grade</b>	F
<b>Voltage</b>	1 Phase 220~240V 50/60Hz	<b>Total Power Watts</b>	1500
<b>Standard Lifting Height</b>	13 ft / 4 m	<b>Power Cord Length and Phase Order</b>	3 ft / Black L1, White, Green ground
<b>Speed (f/m) / min</b>	ft @60Hz 1.5~9.6 mt @50Hz	<b>Recommended Hoist Protection Circuit Breaker AMPs and Type</b>	Type D 10A
<b>Number of Speeds</b>	Variable Speed	<b>Optional Load Chain Brand &amp; Country of Origin</b>	FEC Japan
<b>Hoist VFD Power</b>	1.5kW	<b>Load Chain Type</b>	G100 Nikel
<b>Hoist VFD Brand</b>	HUAYUAN	<b>Load Chain Size</b>	5mm
<b>VFD Model</b>	Z230	<b>Chain Falls</b>	1
<b>Brake Resistor Kw</b>	0.3Kw	<b>Chain Length</b>	13
<b>Duty Class</b>	H4/M5/2m/Class D	<b>Load Chain weight per foot [lbs]</b>	0.36
<b>IEC Hoist IP Protection</b>	IP55	<b>Humidity</b>	20%~90%
<b>IEC Motor Protection</b>	IP55	<b>Temperature</b>	-4 ~ 104° F / -20 ~ 40° C
<b>Pendant Control Yes No</b>	Yes	<b>Transmission / Reducer Type</b>	Spur gearbox
<b>IEC Pendant Control Protection</b>	IP66	<b>Reducer Lubrication Type</b>	Oil
<b>Pendant Control Emergency Stop</b>	Yes	<b>Paint Specifications</b>	Electrostatic Sprayed Plastic (ESP) Epoxy resins, Polyester Resins, Barium, Pigments
<b>Pendant Control total Length</b>	10 ft	<b>Standards Compliance</b>	ASME HST-1 , ASME B30.16 , EN60204-36
<b>Hoist Motor Power in KW</b>	0.5	<b>Standards Certified</b>	CE

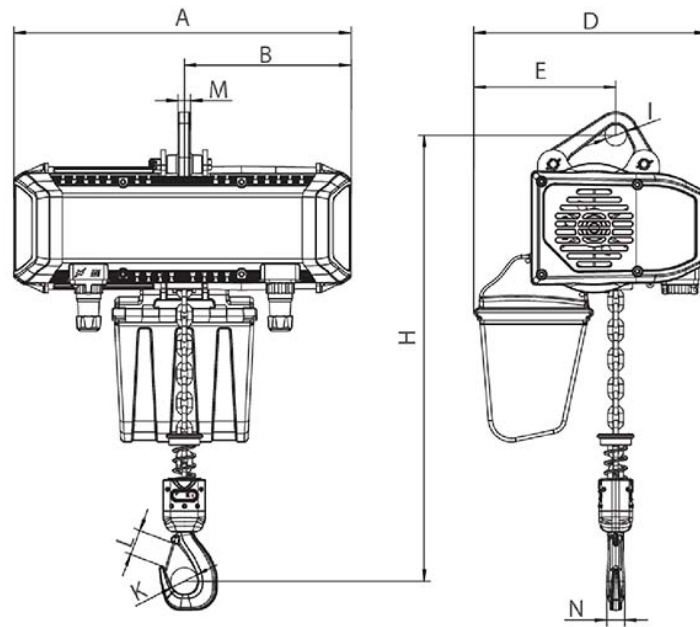

[Size list: mm]

Rated load (t)	Type	Minimum distance between hooks: H	A	B	D	E	I	M	N	K	L
0.25	PWRXF0.25-01	385	440	218	305	186	28	16	20	35	31
0.5	PWRXF0.5-01	385	440	218	305	186	28	16	20	35	31

## Unit Weight & Dimensions

A Total Height	385
J Hook Opening	35
W Width	305
H Minimum Headroom	385
D Depth	440
1st Package Type	Wood Crate
Total Weight (w/out cable or Chain)	67
Total Unit Weight	72.16 lbs / 33 Kg

## Packaging Weight & Dimensions

Package 1 Height	20 in / 50.8 cm
Package 1 Net Weight	72.16 lbs / 33 Kg
Package 1 Width	15 in / 38.1 cm
Package 1 Gross Weight	85.8 lbs / 39 Kg
Package 1 Length	20 in / 50.8 cm