



## **1/4 ton Electric Chain Hoist Variable Speed 110V 1ø 60HZ 13ft G100 Nickel Duty H4/M5**

### **Key features**

- Capacity: Lifts up to 1/4 ton (approximately 500 lbs)
- Power Supply: 110V single-phase, 60Hz for easy compatibility
- Speed Control: Variable speed operation for precise lifting and lowering
- 3 Year Warranty, Customer Support and Service in the USA

### **Electric Chain Hoist Description**

The 1/4 Ton Electric Chain Hoist is a versatile and powerful lifting solution designed for a wide range of applications. With variable speed control and a 110V single-phase 60Hz power supply, this hoist offers precision and efficiency in handling lighter loads. Its robust construction ensures reliability and safety, making it suitable for both industrial and DIY projects.

## Technical Specifications

<b>Rated Load Capacity</b>	1/4 ton	<b>Chain Falls</b>	1
<b>Standard Lifting Height</b>	13 ft / 4 m	<b>Chain Length</b>	13
<b>Speed (f/m) / min</b>	ft @60Hz 1.5~9.6 mt @50Hz	<b>Humidity</b>	20%~90%
<b>Number of Speeds</b>	Variable Speed	<b>Temperature</b>	-4 ~ 104° F / -20 ~ 40° C
<b>Voltage</b>	1 Phase 110~120V 60Hz	<b>Standards Compliance</b>	ASME HST-1 , ASME B30.16 , EN60204-36
<b>Total Power Watts</b>	1500	<b>Warranty</b>	3 Year
<b>Duty Class</b>	H4/M5/2m/Class D	<b>Hoist VFD Power</b>	1.5kW
<b>IEC Motor Protection</b>	IP55	<b>Hoist VFD Brand</b>	HUAYUAN
<b>Control</b>	Pendant Control IP66 and Industrial Wireless Control	<b>Hoist Motor Power in KW</b>	0.5
<b>Control Voltage</b>	24V	<b>Hour Meter</b>	Internal Working Hour Meter
<b>Emergency Stop</b>	Yes	<b>Hoist Motor Insulation Grade</b>	F
<b>Transmission / Reducer Type</b>	Spur gearbox	<b>IEC Hoist IP Protection</b>	IP55
<b>Load Chain Type</b>	G100 Nikel	<b>IEC Pendant Control Protection</b>	IP66
<b>Load Chain Size</b>	5mm	<b>Hoist Motor Brake Type and DC Voltage</b>	DC170V

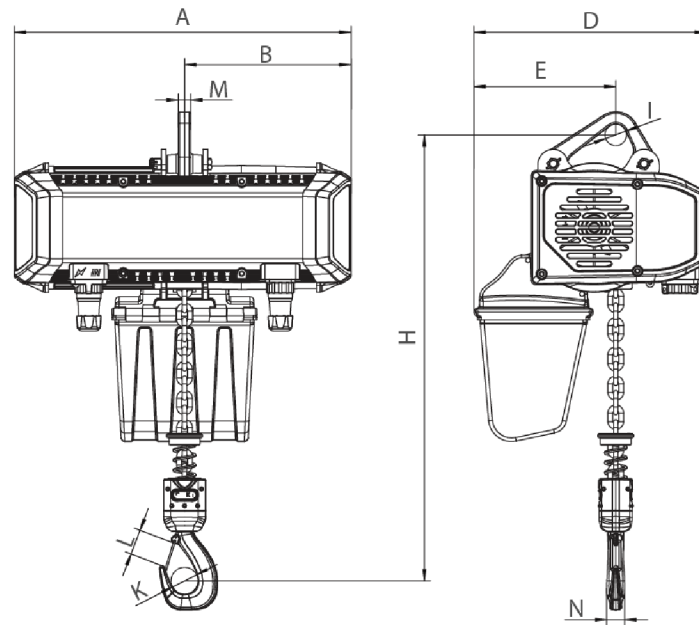

[Size list: mm]

Rated load (t)	Type	Minimum distance between hooks: H	A	B	D	E	I	M	N	K	L
0.25-0.5	PWRXF0.25-0.5-VS	399	447	217	337	179	31	16	20	35	31

## Unit Weight & Dimensions

H Minimum Headroom	385
J Hook Opening	35
A Total Height	385
Total Weight (w/out cable or Chain)	67
D Depth	440
1st Package Type	Wood Crate
W Width	305
Total Unit Weight	72.16 lbs / 33 Kg

## Packaging Weight & Dimensions

Package 1 Net Weight	72.16 lbs / 33 Kg
Package 1 Width	15 in / 38.1 cm
Package 1 Gross Weight	85.8 lbs / 39 Kg
Package 1 Height	20 in / 50.8 cm
Package 1 Length	20 in / 50.8 cm